

Peter Scherschligt - 2026 Portfolio

A collection of projects completed at the University of Minnesota



Coleman  **SIPHONBREW**
A portable coffee solution



 **CASCADE**
A simpler solution for automatic litter filtering



MUJI  **DESK ACCESSORIES**
Creating a naturally organized space



Hi I'm Peter!

Senior Product Design student at the University of Minnesota

I like to say that I have always been a designer, I just didn't know it. From a young age I have been a maker, artist, thinker, and problem solver. Now I have the resources to apply these skills to a field I love, and to continue improving myself as a designer.

Education

2026 Expected

University of Minnesota
B.S. Product Design

Experience

Jan 2026 - Present

Student Ambassador
Color Material Group

September 2025 - Present

Teaching Assistant
U of MN College of Design

May 2025 - August 2025

Industrial Design Intern
Tennant Company

Skills

Design Methods

Sketching
Surfacing
Prototyping
3D modeling
DFM

Prototyping & Fabrication

3D Printing
Fabrication and model-making
CNC
Laser cutting
Plasma cutting

Tools



Solidworks



Keyshot



Photoshop



Rhino



Figma



Illustrator



Gravity Sketch



Fusion



Premier



SIPHONBREW

**A PORTABLE POWERED BREWING
METHOD FOR CAMPERS**

2024 - 12 Weeks



THE LIFELONG CAMPER

A lifelong instant coffee drinker in need of a better brew



Too bland



Too heavy



Too smart

HOW MIGHT WE HELP CAMPERS MAKE HIGHER QUALITY COFFEE WITHOUT SACRIFICING SIMPLICITY?

SIPHON BREWING

A NON ELECTRIC WAY TO VACUUM BREW COFFEE

Siphon technology pulls a high quality brew without any moving parts or electronics making it ideal for camping



HOW DOES IT WORK?

01

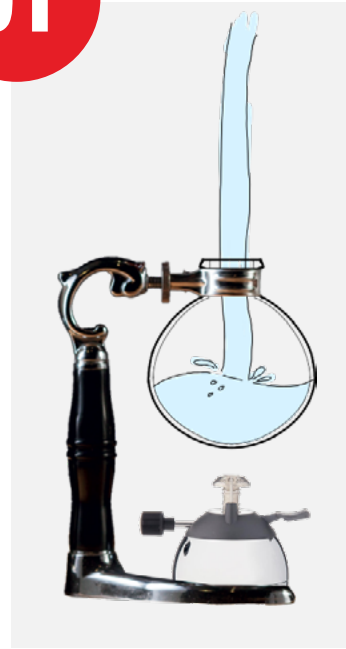

Add Water

02

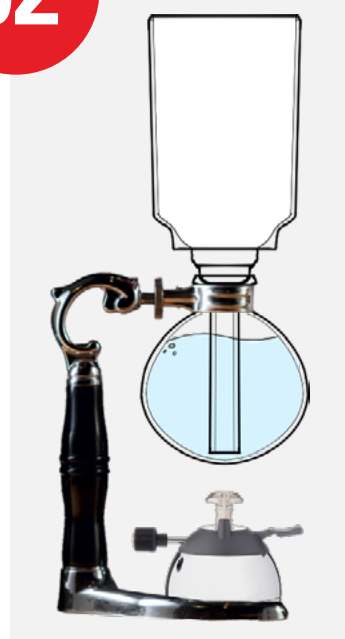

Seal Chamber

03

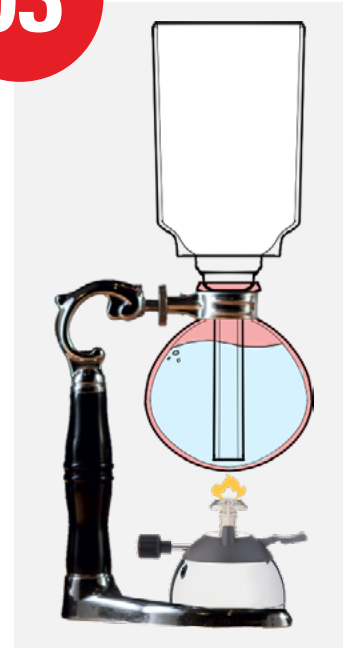

Apply Heat

04

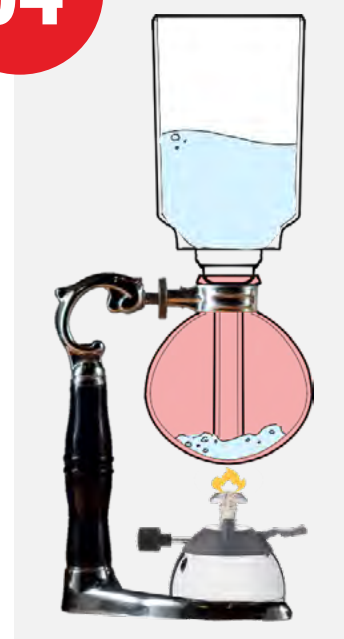

Let Upper Reservoir Fill

05

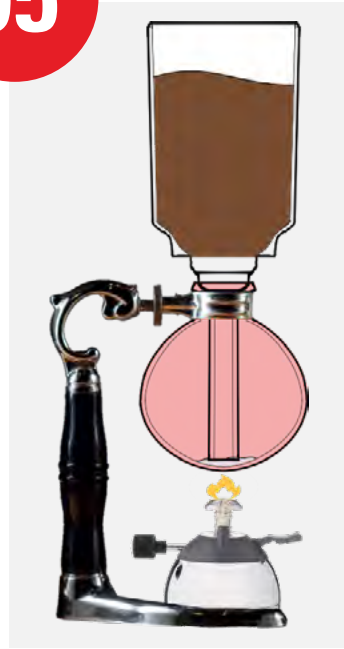

Add Coffee

06

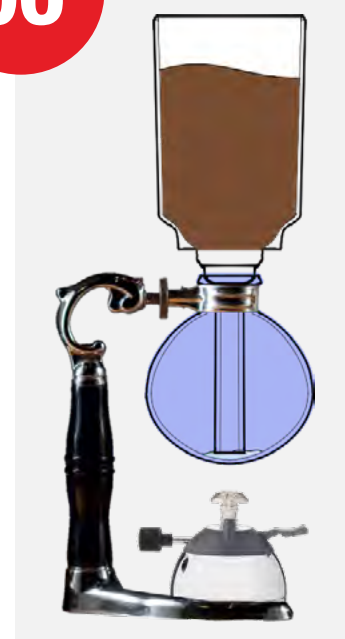

Remove Heat

07



Vacuum Filter

08



POUR AND ENJOY

As the coffee sits in the lower reservoir the burner can be adjusted to keep the coffee warm or cool.



CAMPFIRE POWERED



**COLEMAN BRAND
LANGUAGE**



PORTABLE



DURABLE



4-6 CUP CAPACITY



DESIGN CRITERIA

STANDARD FILTER



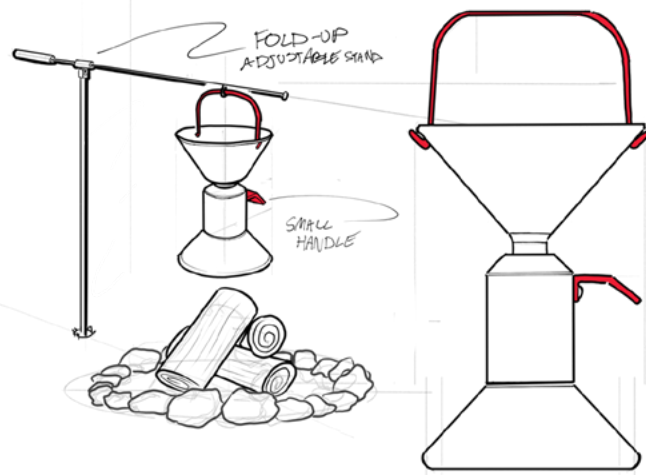
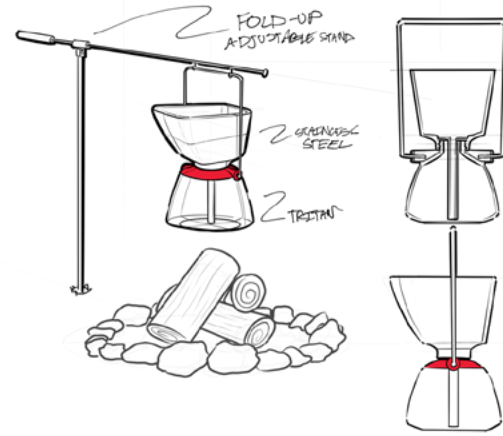
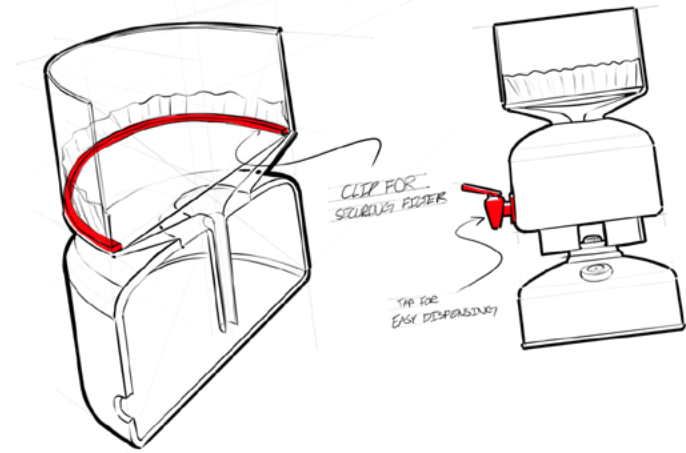
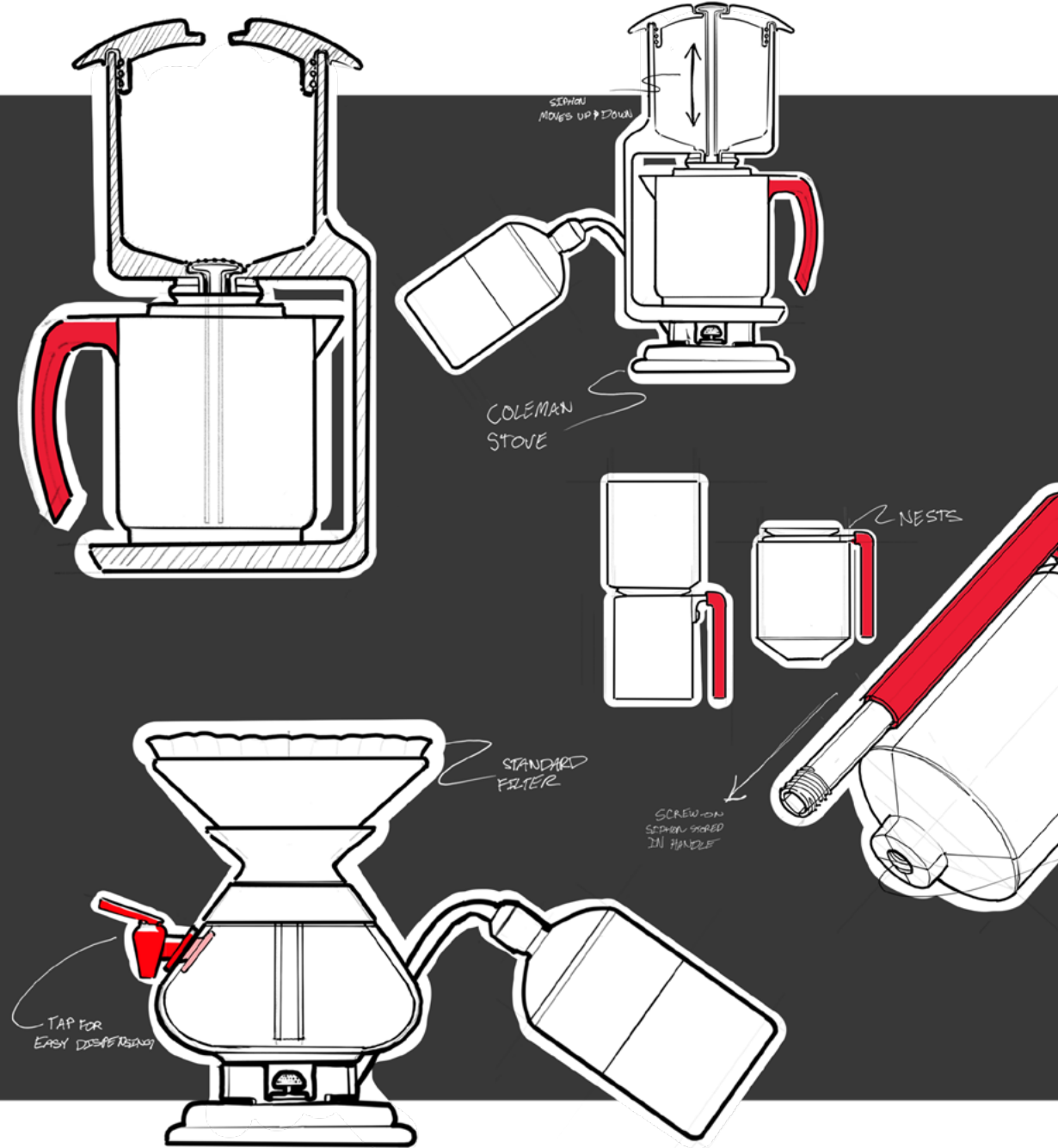
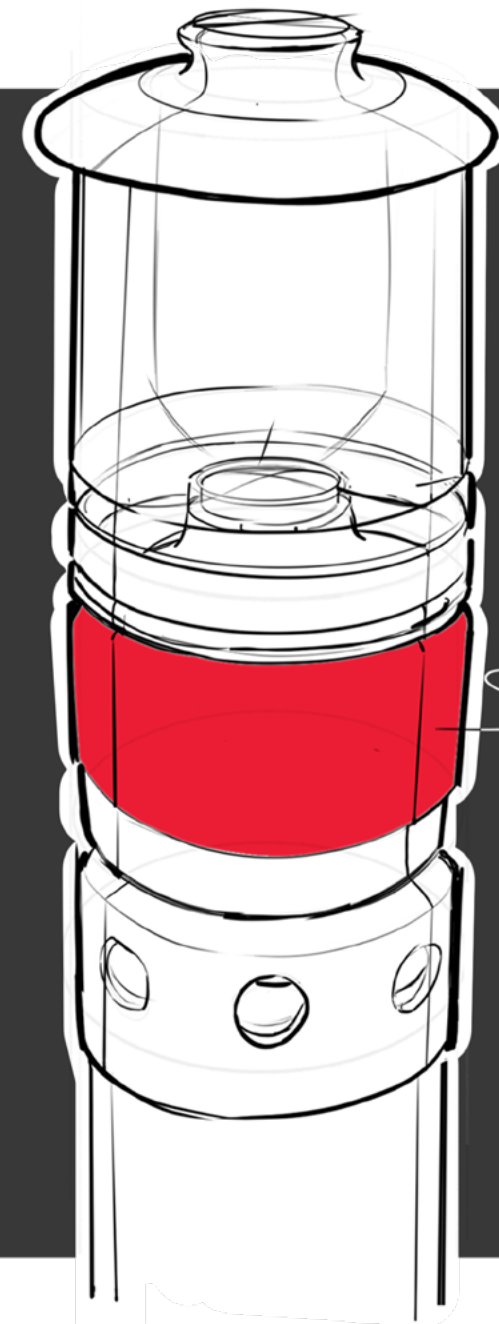
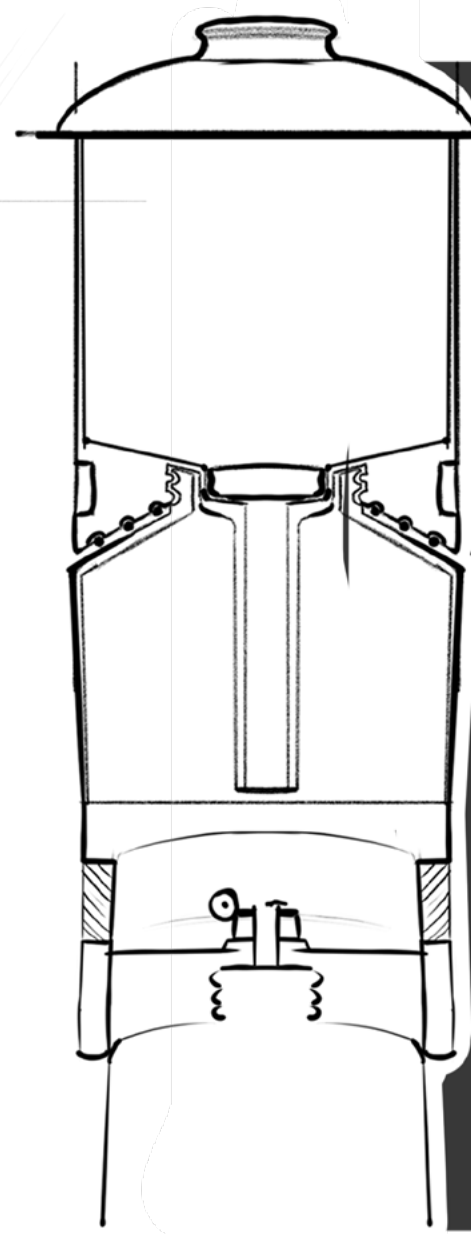
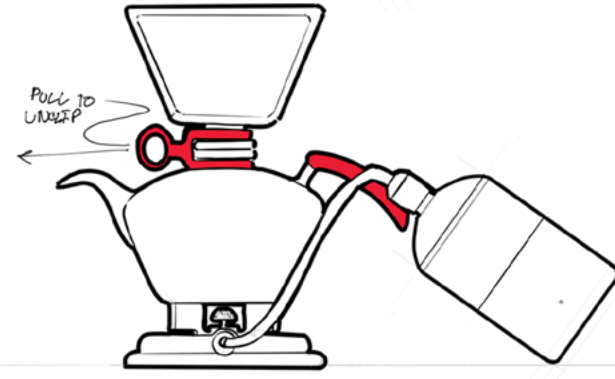
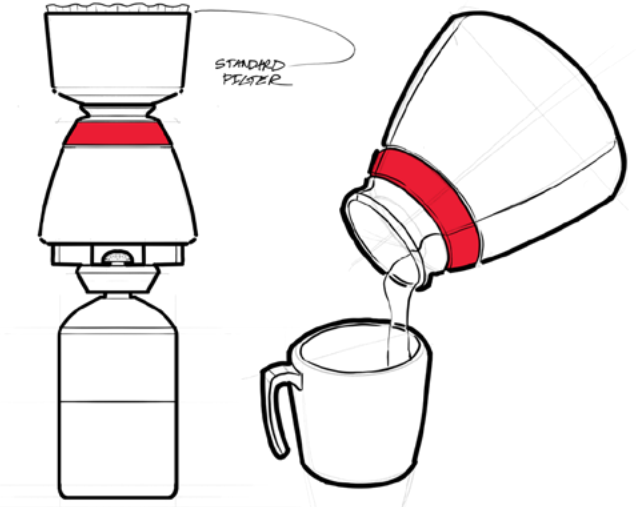
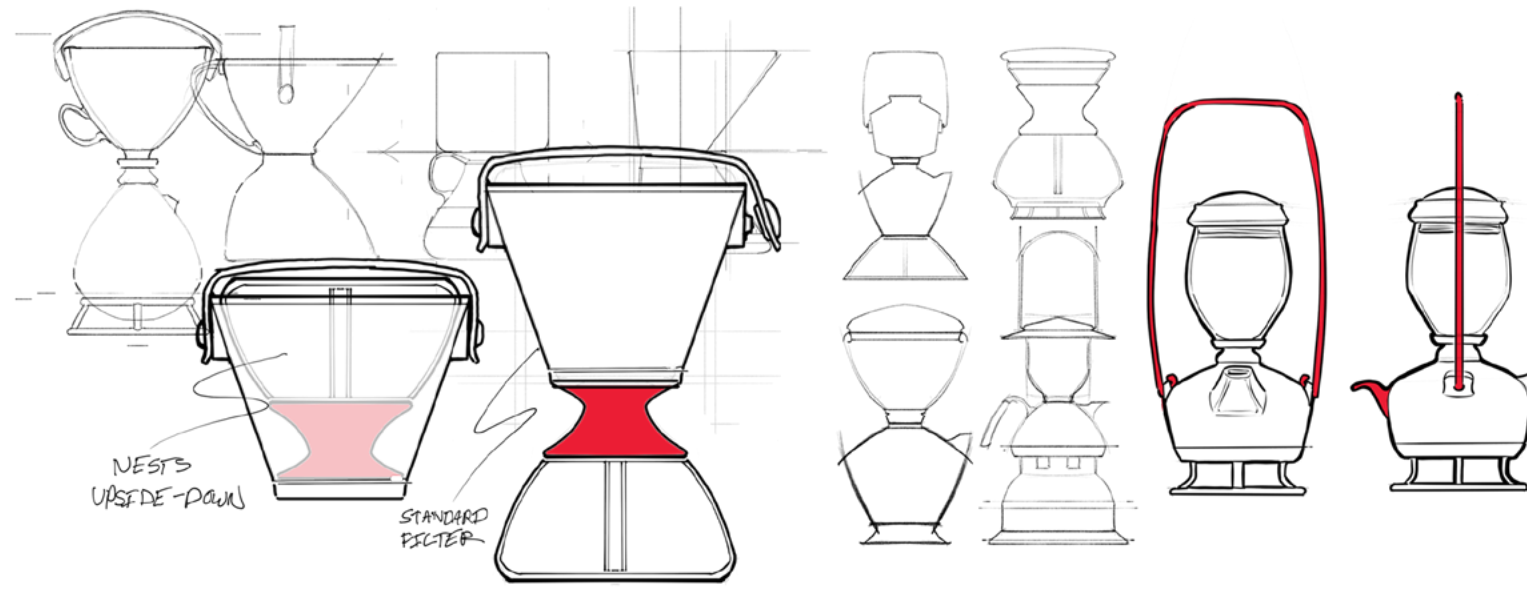
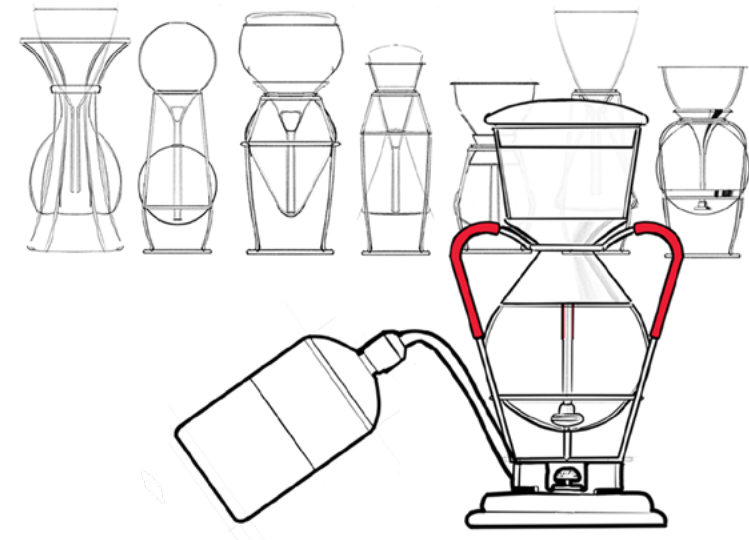
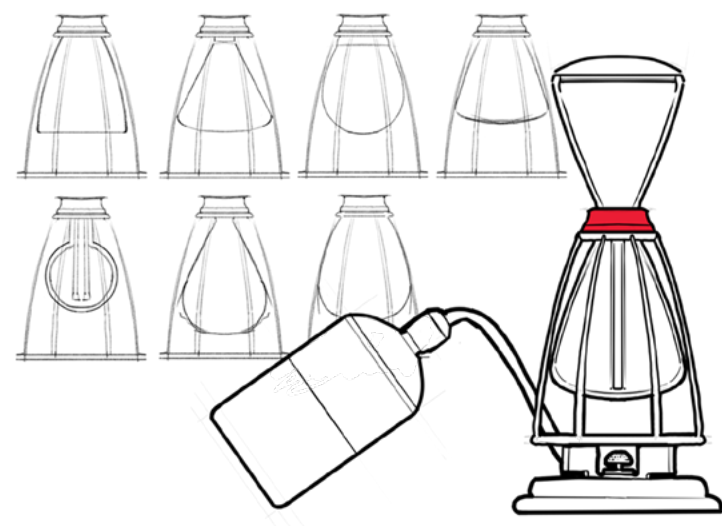

SILICON GRIP

STANDARD COLEMAN PROPANE

COLEMAN STOVE

THREADS FOR SIPHON

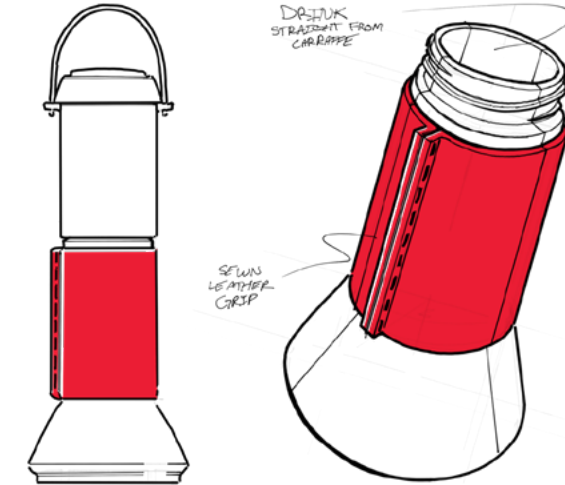
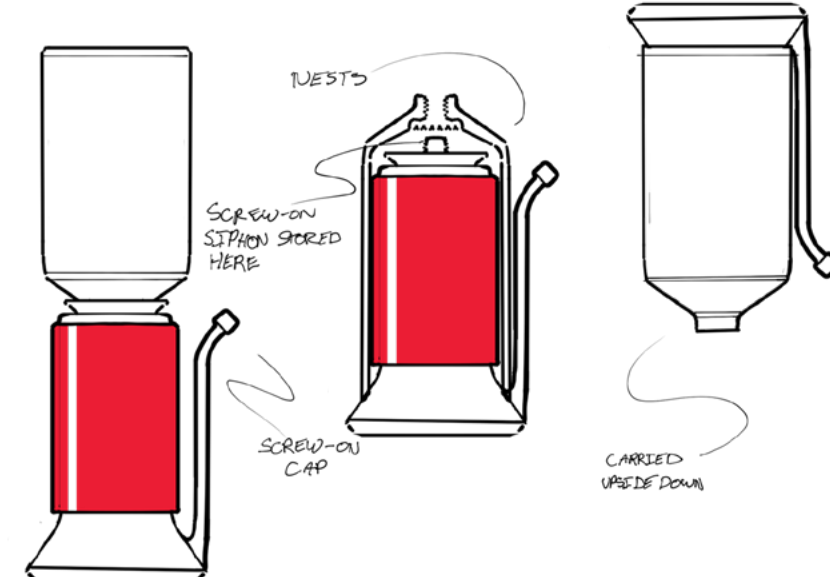
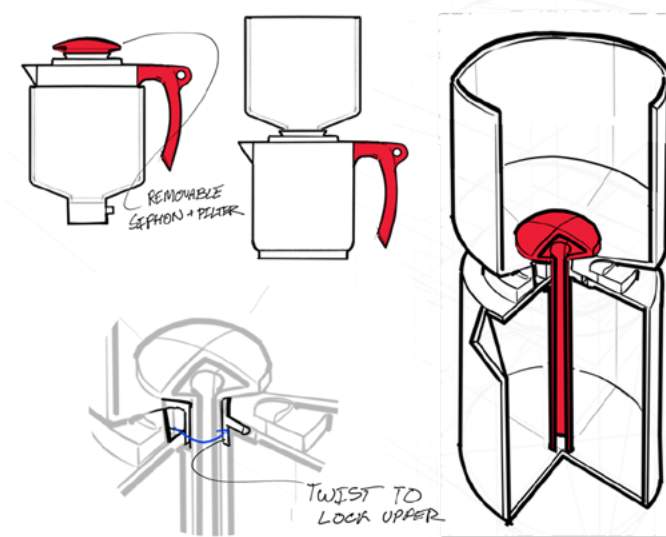
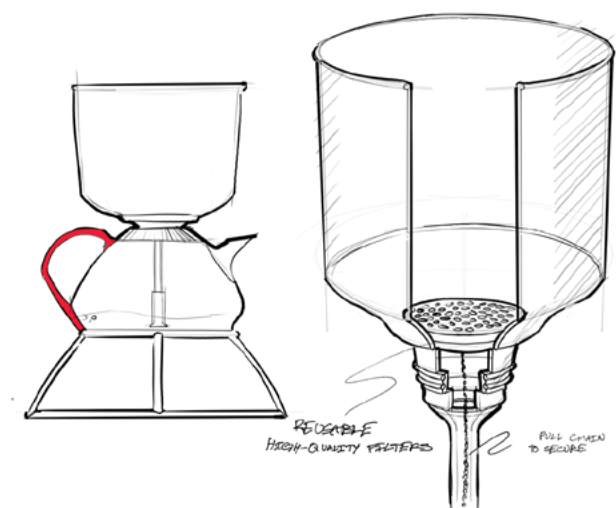
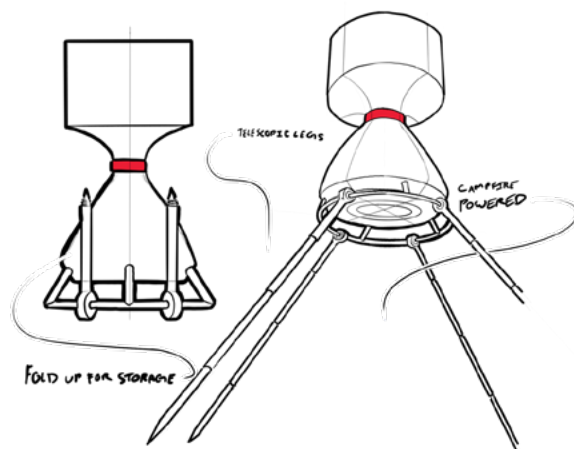
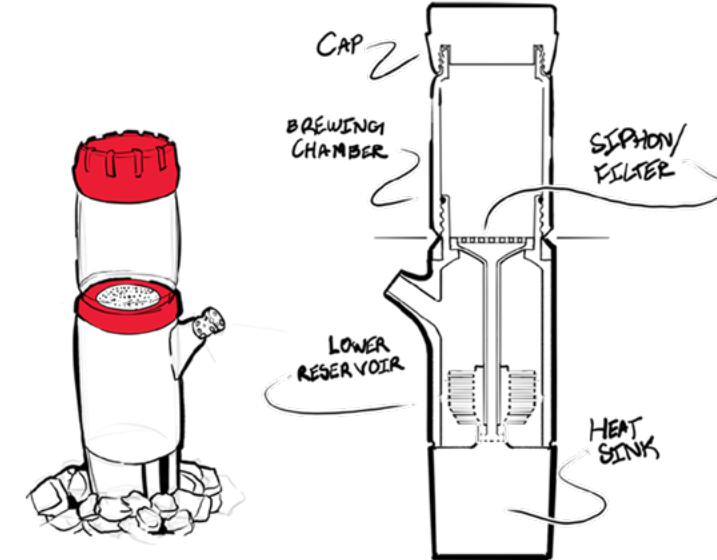

IDEATION

A portable, stovetop coffee maker for 1-4 serious campers

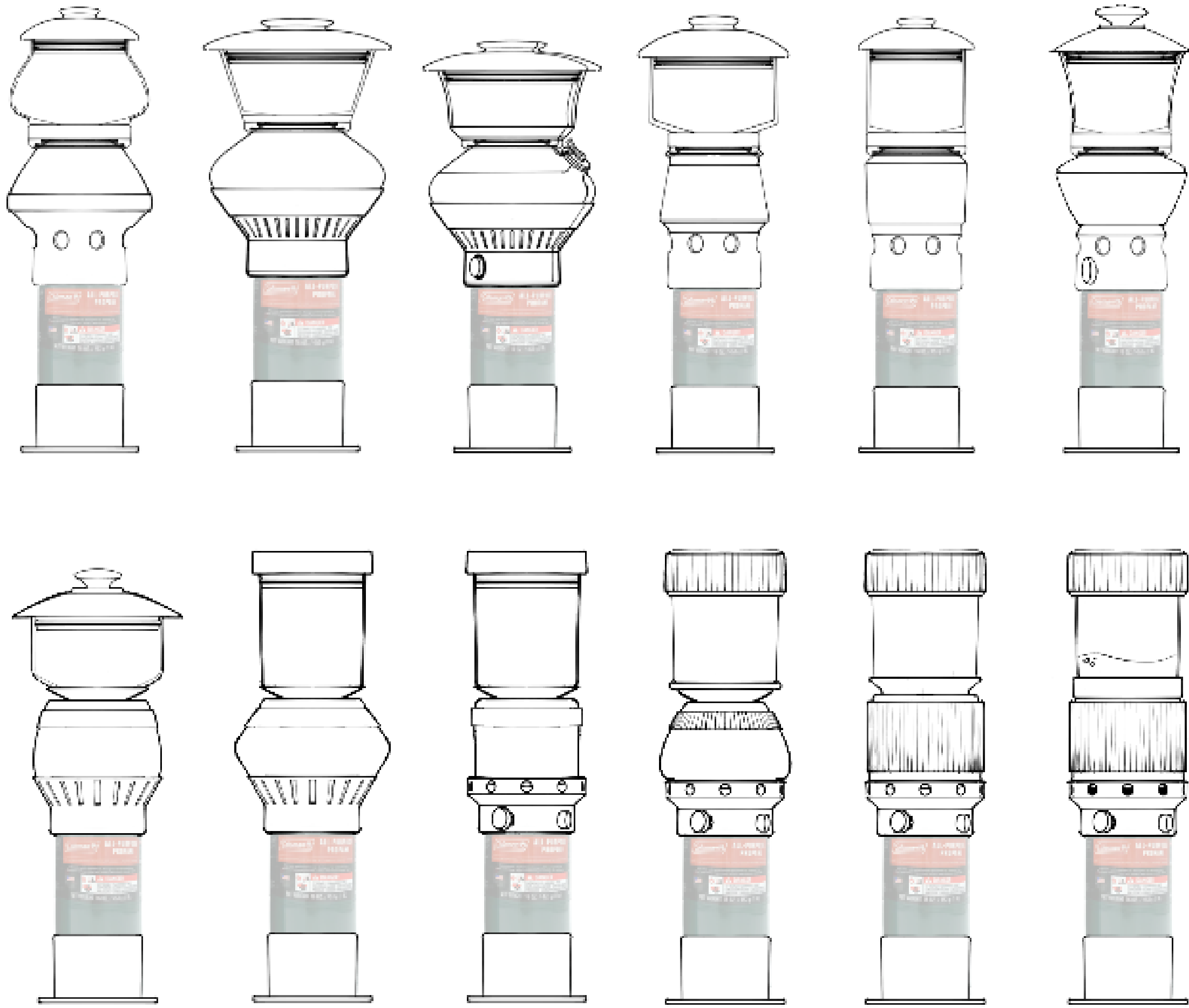
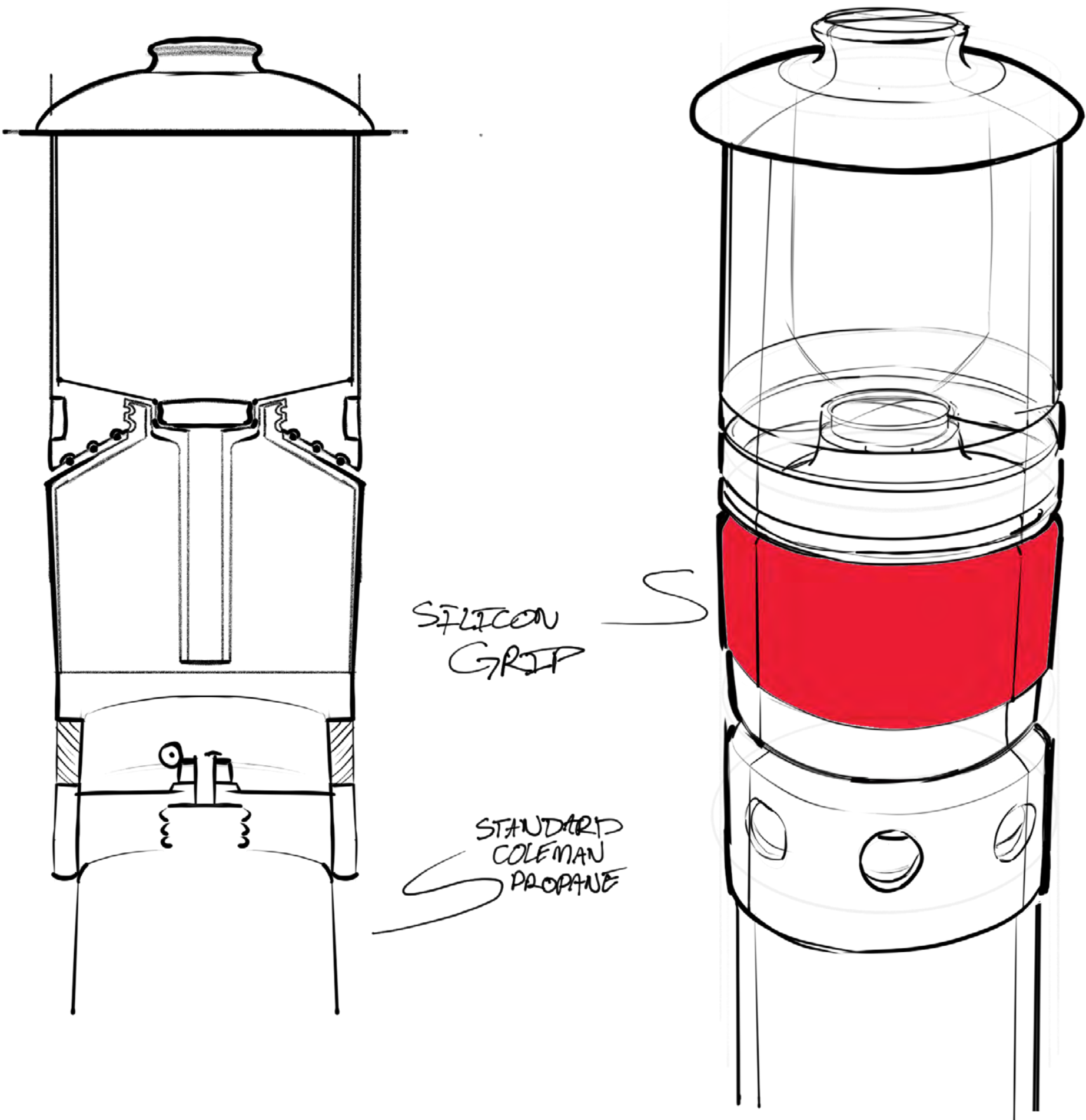

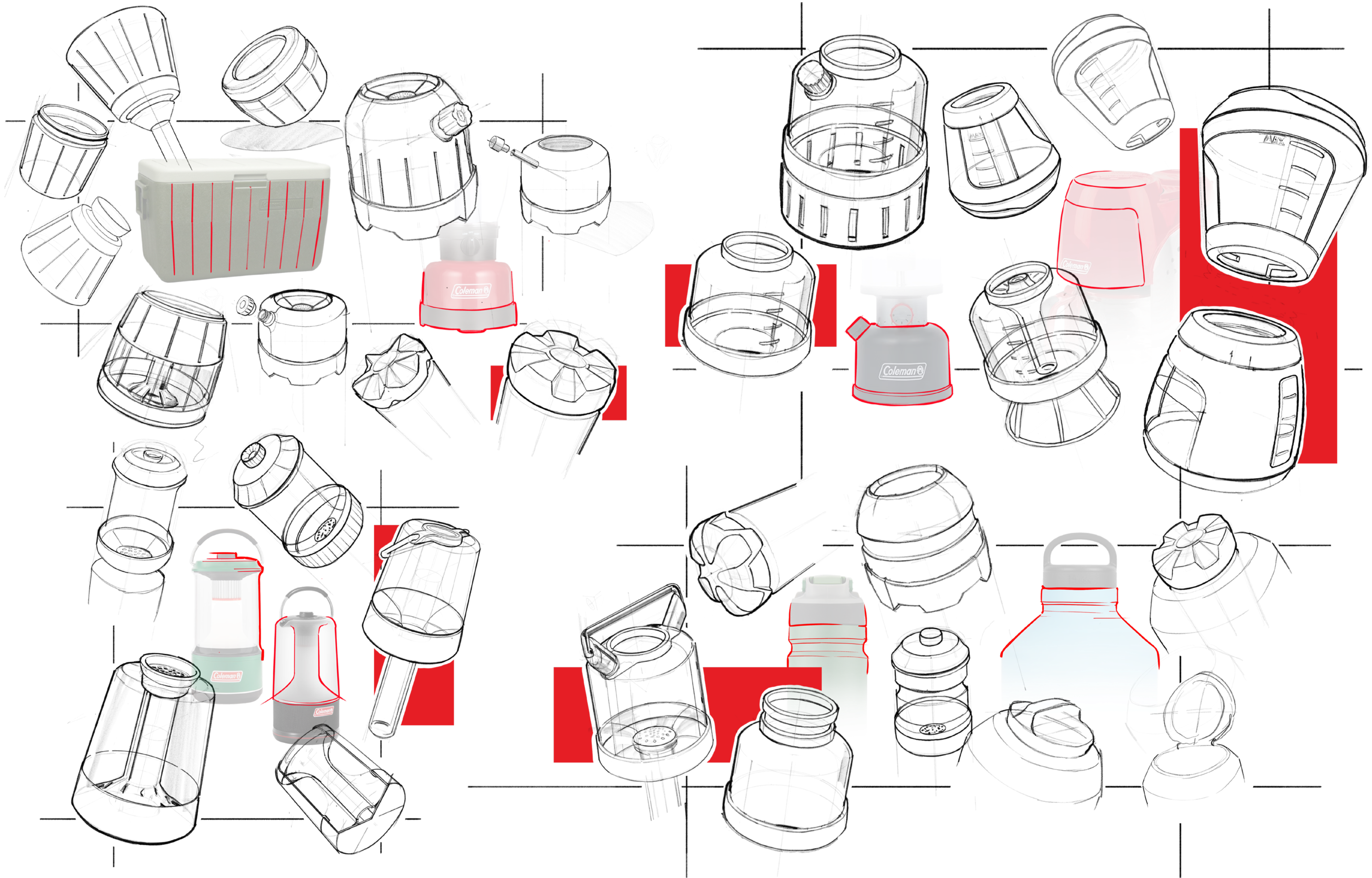

FORM ITERATION

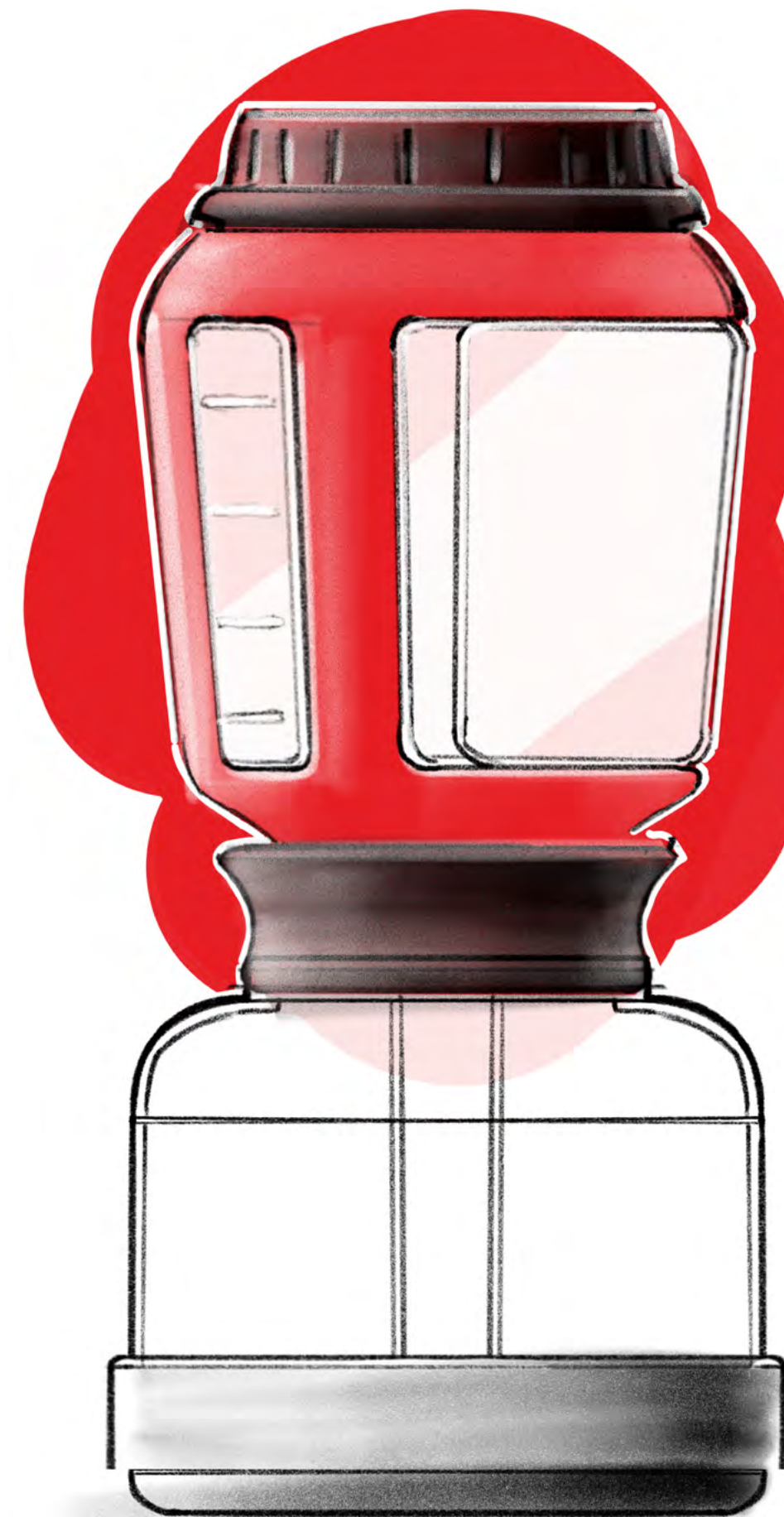
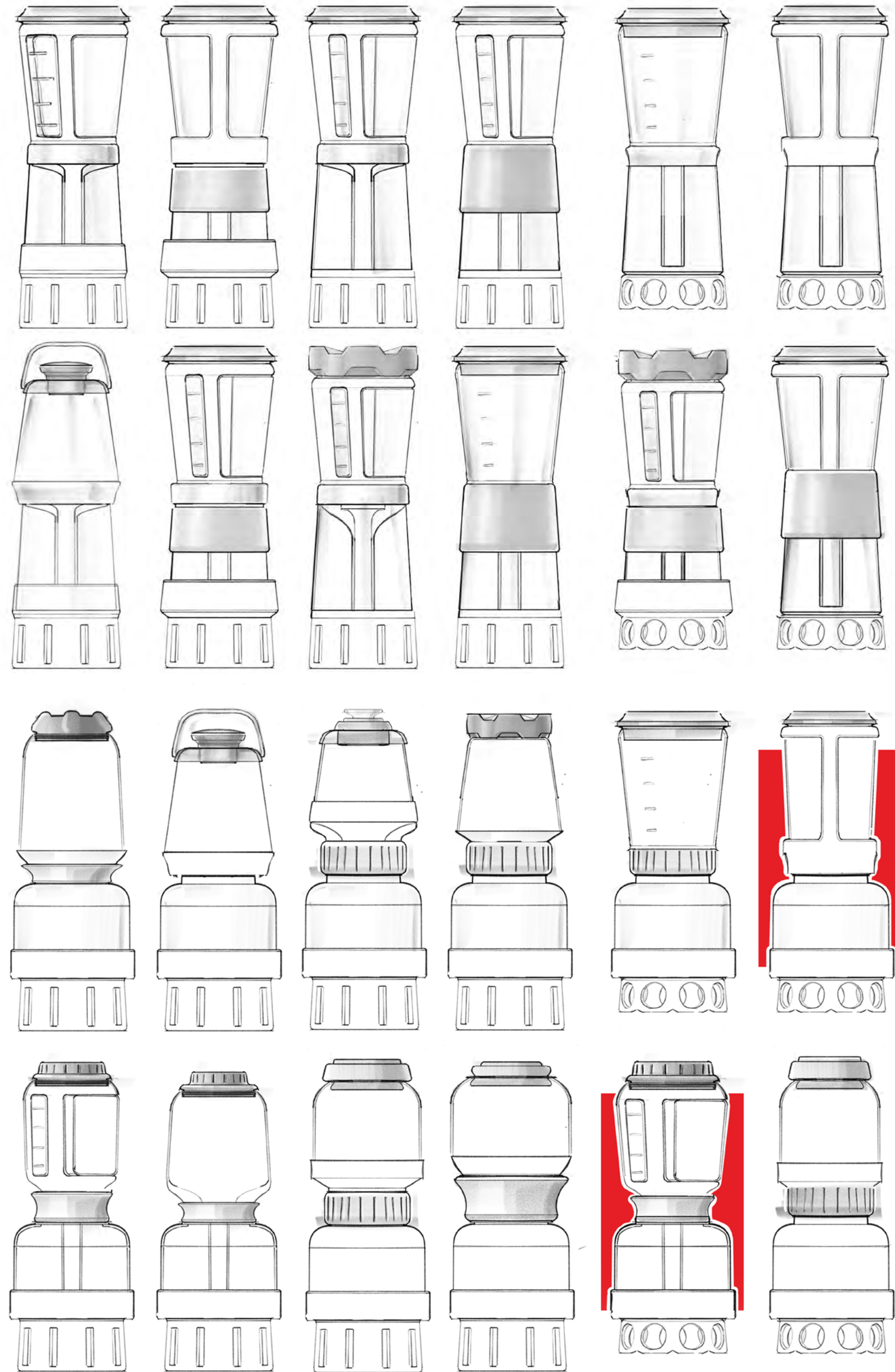

FORM ONE

- Screw on lid
- Three parts
- Metal base

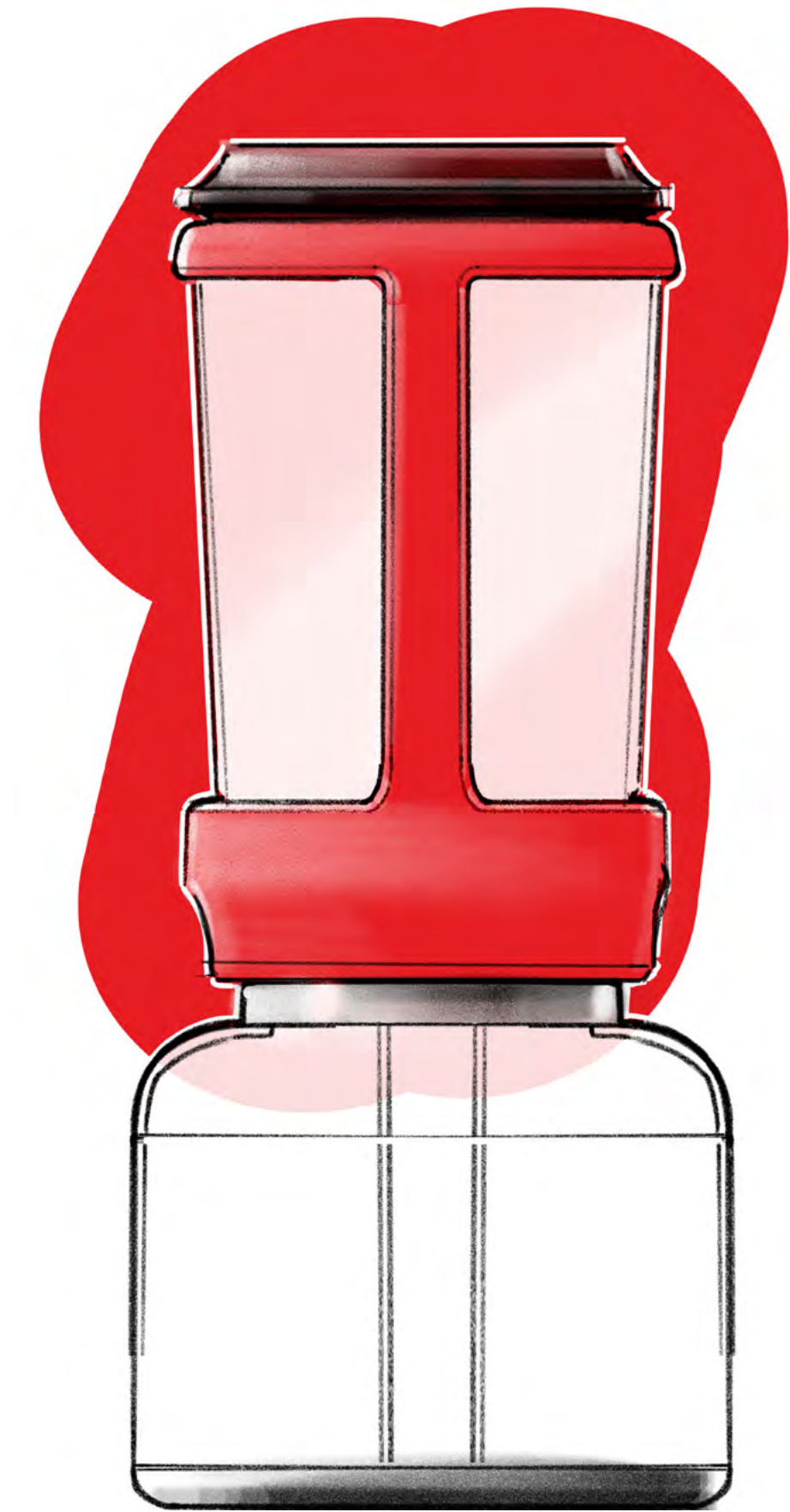

FORM TWO

- Pop off lid
- Two parts
- Small metal ring on base

FORM DEVELOPMENT

After deciding on the first form I experimented with proportions and features in order to finalize a form that could be sculpted in HDU foam

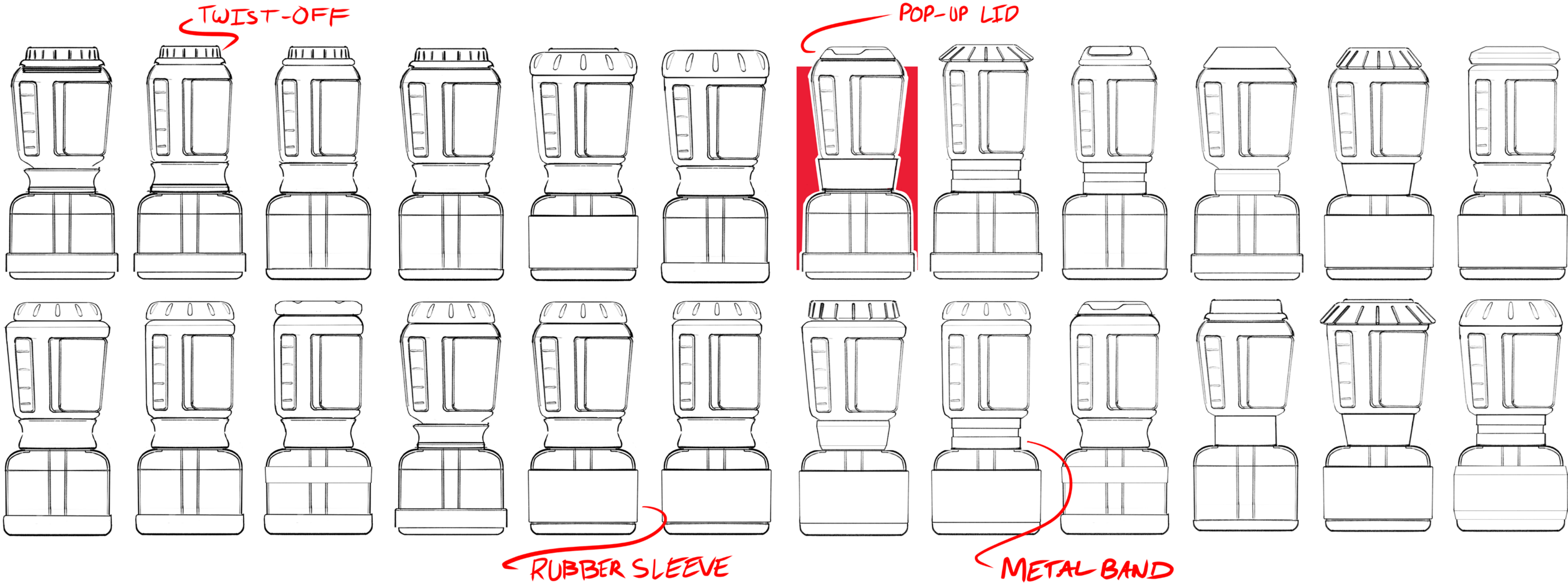
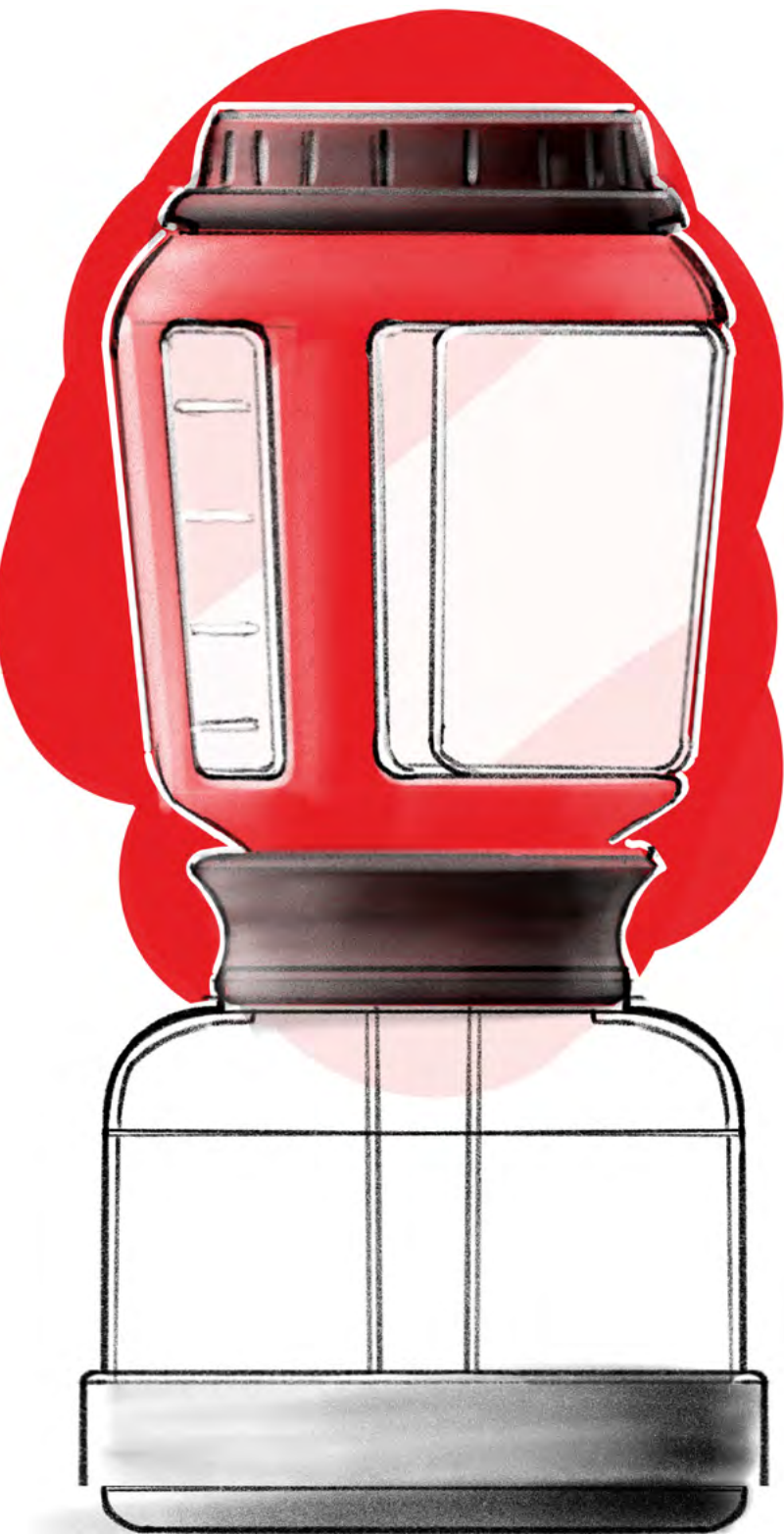

HANDLE REFINEMENT

I refined the handle by switching between solidworks and ideating in photoshop using overlays, trying to follow the general form of similar handles like cork pourover carafe handles and large handle-less water bottle.

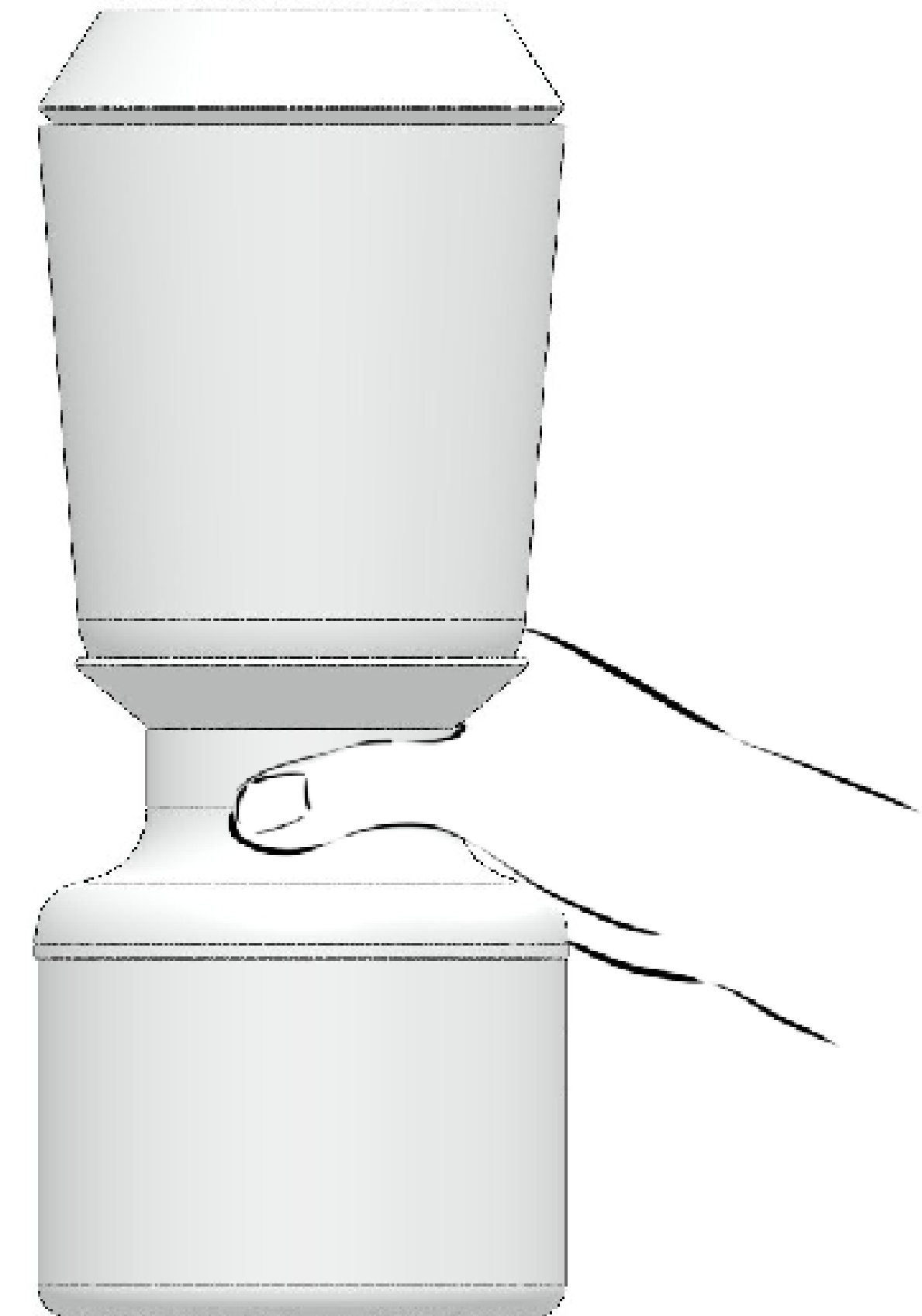
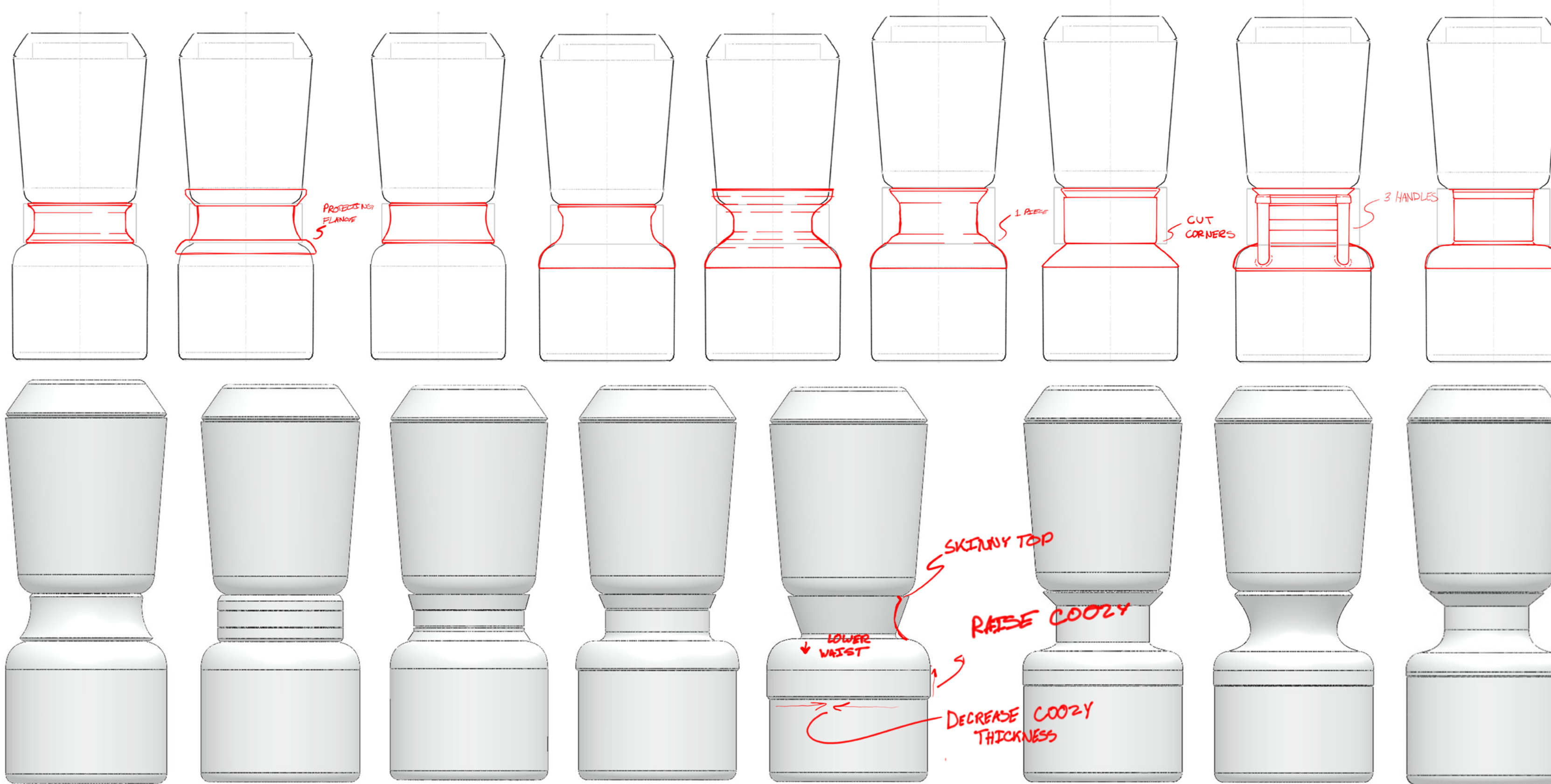



SIPHON BREW

FINAL CONCEPT SKETCH

Adobe Photoshop

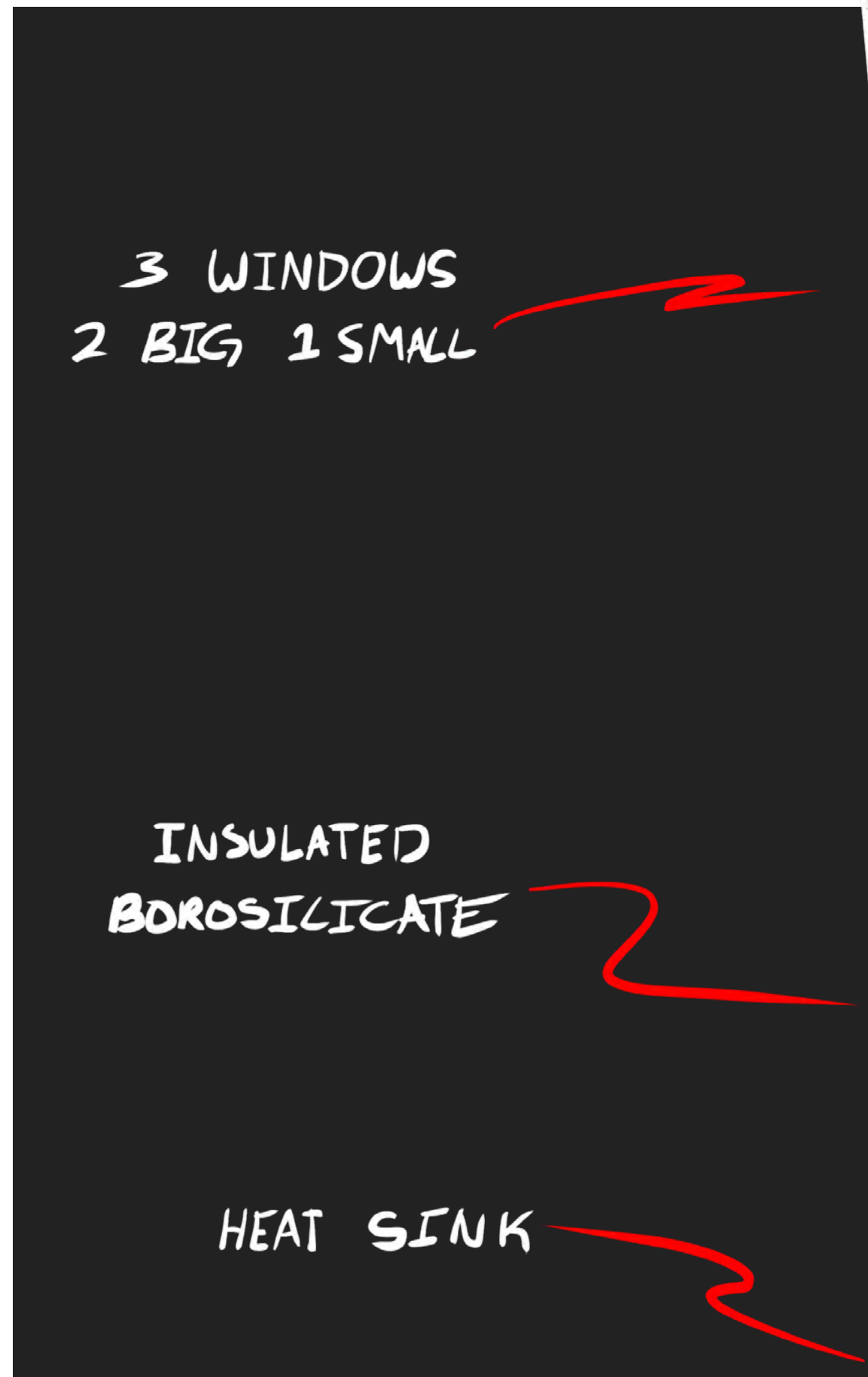
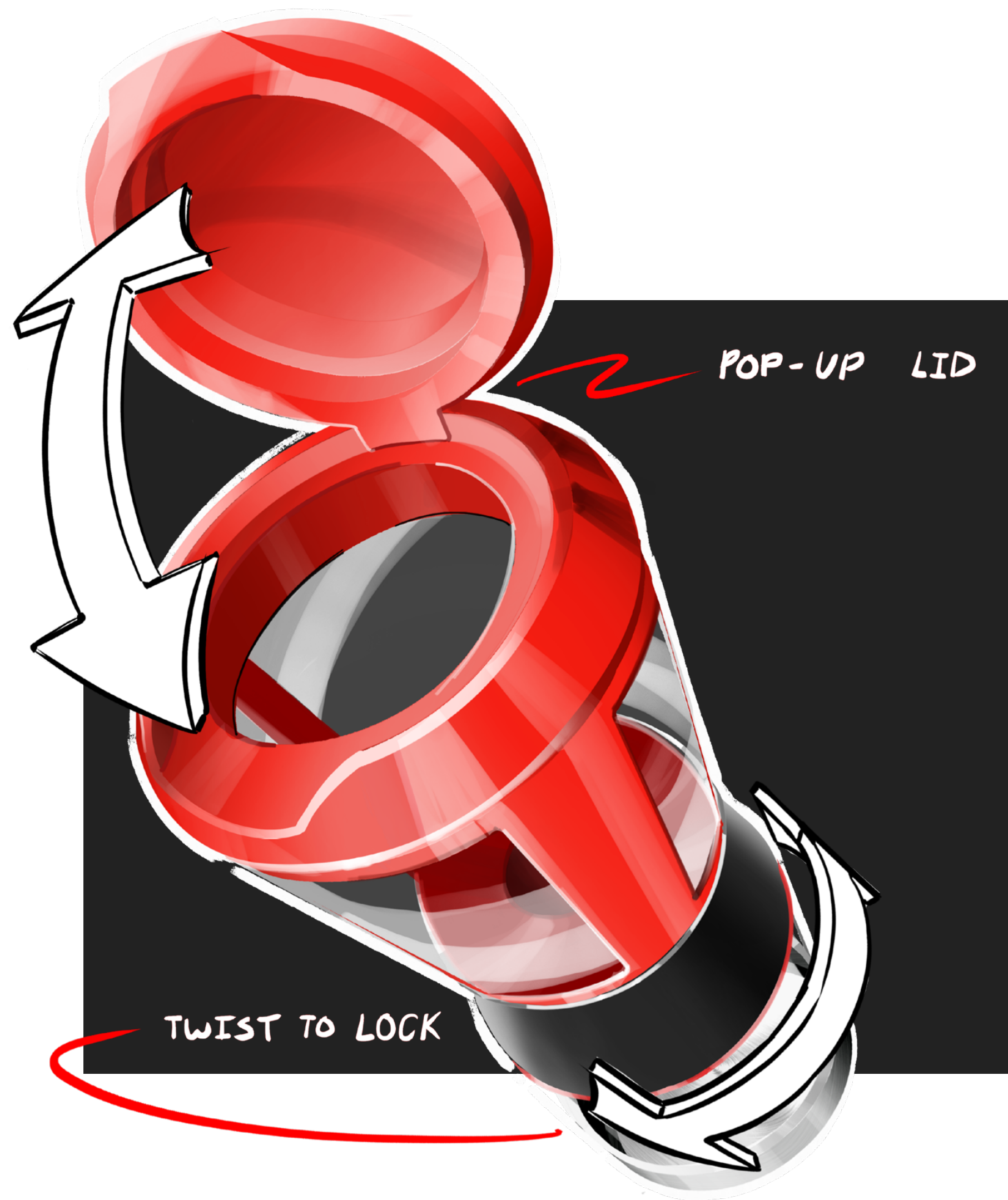



LID

BREWING
CHAMBER

SLEEVE

CARAFE



SIPHONBREW

A Portable, Stovetop Siphon Coffee Maker for 1-4 Campers

PREP

01



Insert filter into brewing chamber

02



Use the scoop to hook the elastic to the bottom of the siphon

03



Screw on lid

04



Add desired amount of water to carafe

05



slot brewing chamber notches into the carafe

06



Twist to lock

BREWING

01



Turn on Heat

02



Wait until all water has left the carafe

03



Add one scoop of grounds per 5 oz of water

04



Stir grounds

05



Wait 2 mins per 5 oz of coffee

06



Turn off Heat

07



Let coffee siphon through filter

08



Remove brewing chamber and let cool

09



Pour and enjoy

NEXT STEPS...

01

Add feature to brewing chamber that keeps the end of the siphon off the ground when removed

02

Add intrigue to more static forms like the neck of the carafe

03

Refine graphics - Add Siphon brew logo, add texture to labels, refine fill level indicators



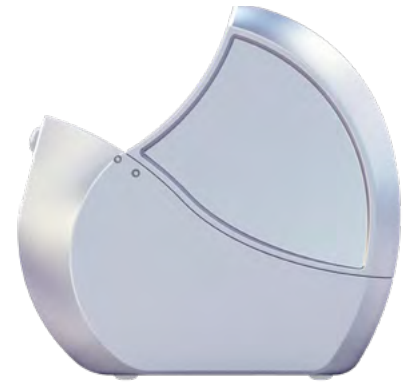

CASCADE

A simpler solution for automatic litter filtering

2025 - 8 Weeks

Senior Research Studio



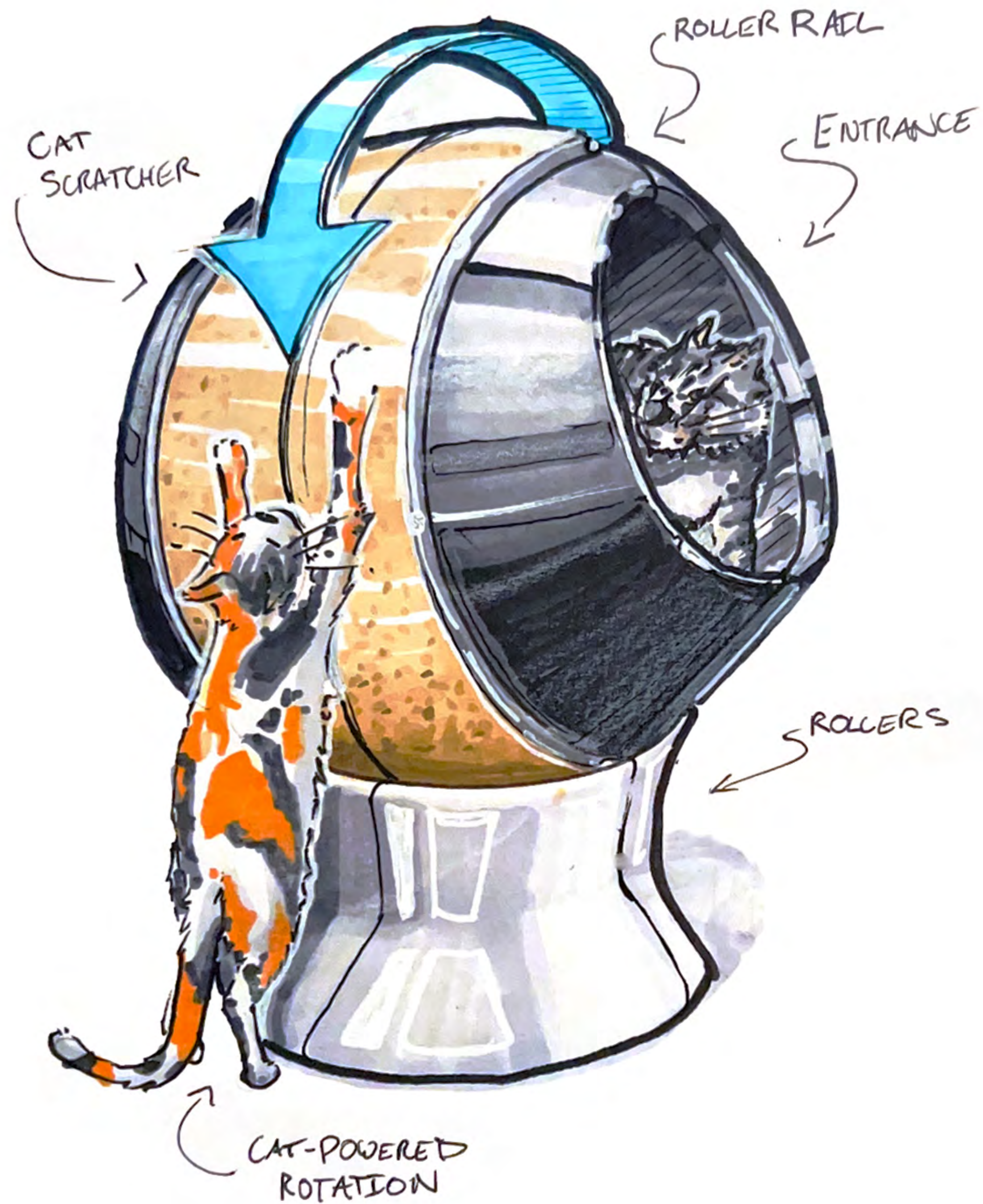

How Might We....

Improve the hygiene of the cat litter cleaning process?

Litter Robot 4



- Industry standard
- App controlled
- \$699 !!!

Cheaper Alternatives



 Motivatedbeast

★★★★★ Verified Purchase

This machine killed my cat!

Reviewed in the United States on July 26, 2024

Color: Grey



Buyer beware this machine killed our family cat of two years she got stuck in this machine and it ended her life do not buy this machine!

Can we make self cleaning litter boxes more accessible?



Research Process



Secondary Data Review

Collected insights from Reddit, Youtube, and Amazon



Observation

Observed the litter process for multiple types of litter boxes



Interviews

3 Interviews from 3 different types of cat owners

Example of Interview



Mykaila

23, Female - 43 minute Zoom interview

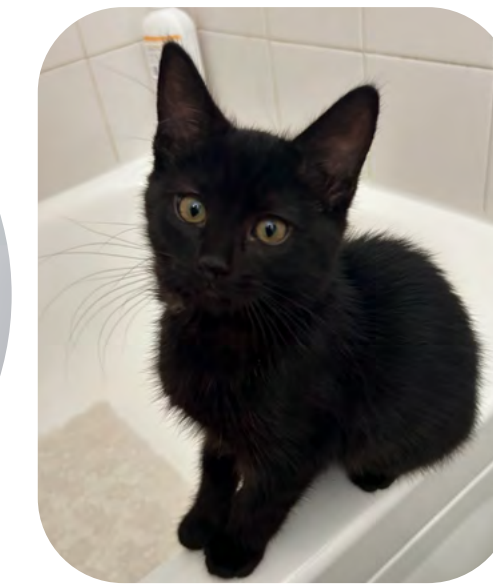

Mau Mau

- **House** - Small apartment
- **Cat** - Young kitten that is learning
- **Food** - Auto wet food feeder
- **Water** - Gravity water bowl
- **Litter Box** - Petmate Giant Litter Pan
- **Litter Brand** - Tofu Litter
- **Location** - Living room
- **Cleaning Frequency** - Every-other day

Concerns

- Price (willing to pay < \$200)
- Aesthetics (wants it to blend in)
- Safety
- Odor containment

Why dont cat owners invest in current solutions?



Expensive

With their current solution currently working, why would they invest that much money?



Complex

Another app on your home screen, password to remember, and features to troubleshoot



Unsafe

Even without knowledge of past accidents, no one wants to surround their veulnerable pet with electronics

My criteria for a viable solution:



Accessibility

Both financial and physical. Should be purchasable and useable for most cat owners.



Easy

It should ease all processes related to litter cleaning above all.



Reliable

No troubleshooting or confusion, and it should keep your cat safe with no concerns.



The best way to learn how something works is to build it

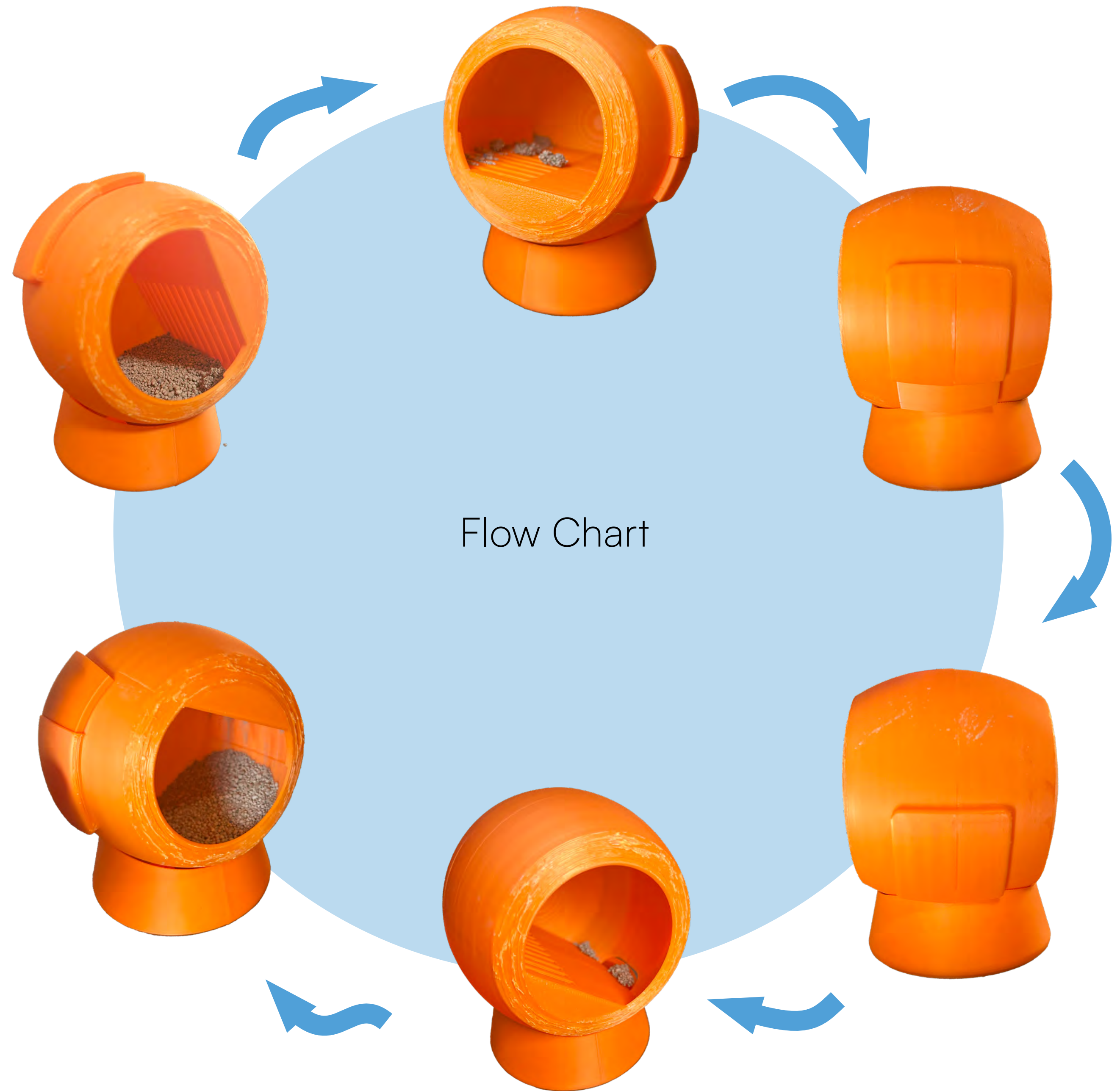

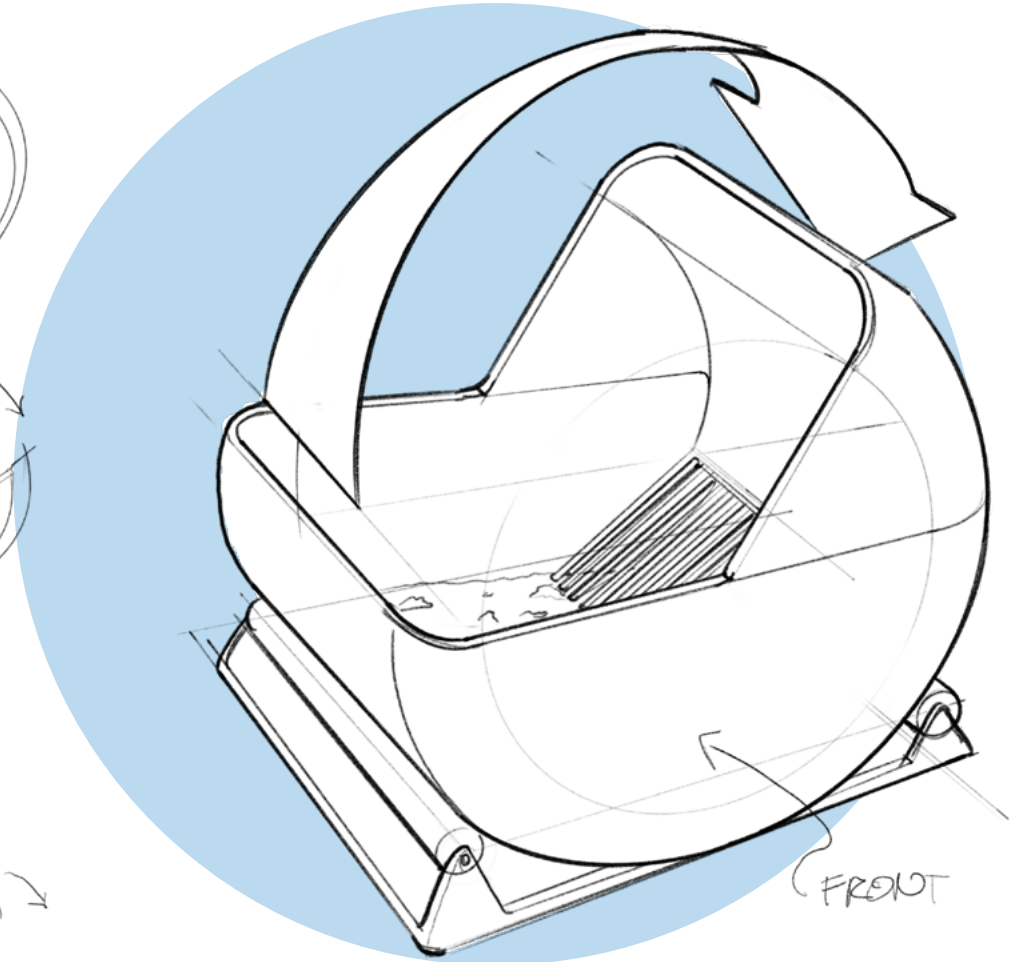
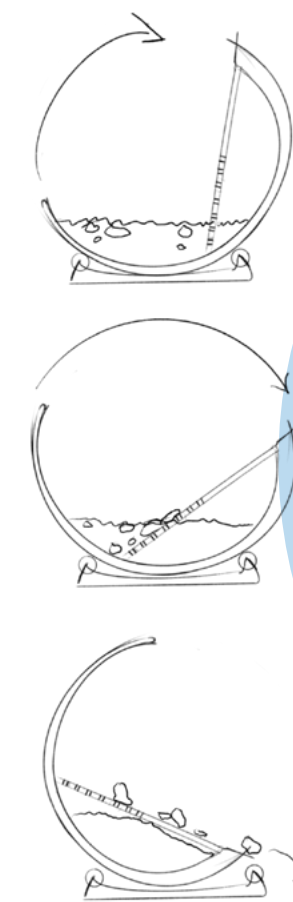
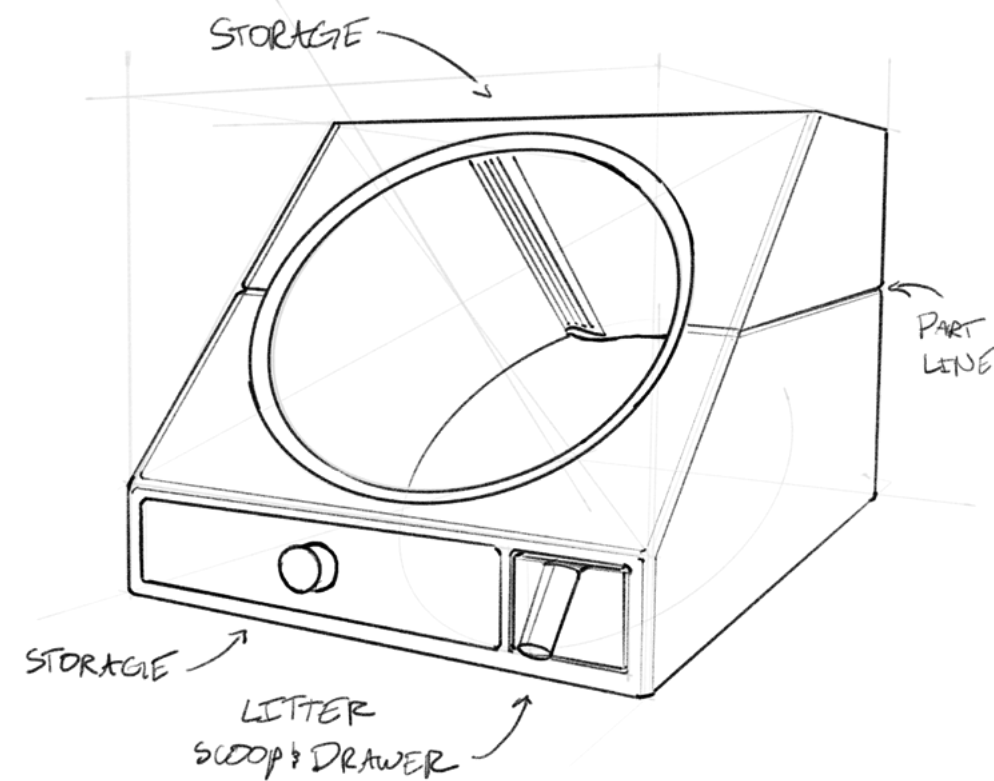
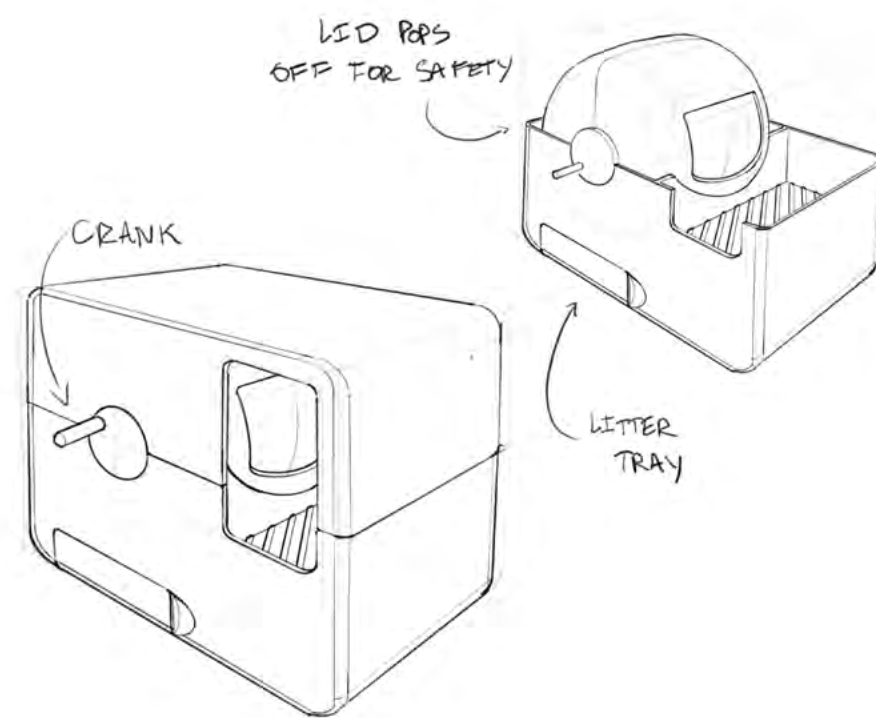
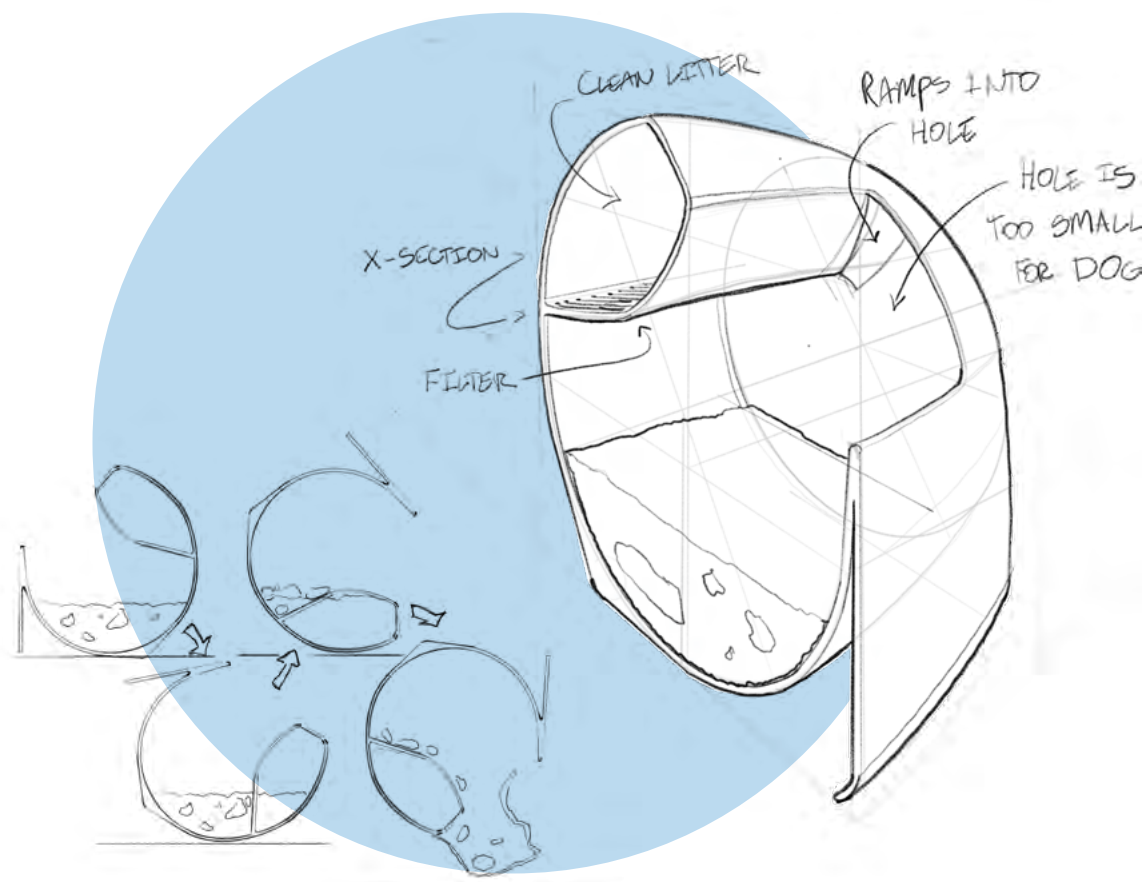
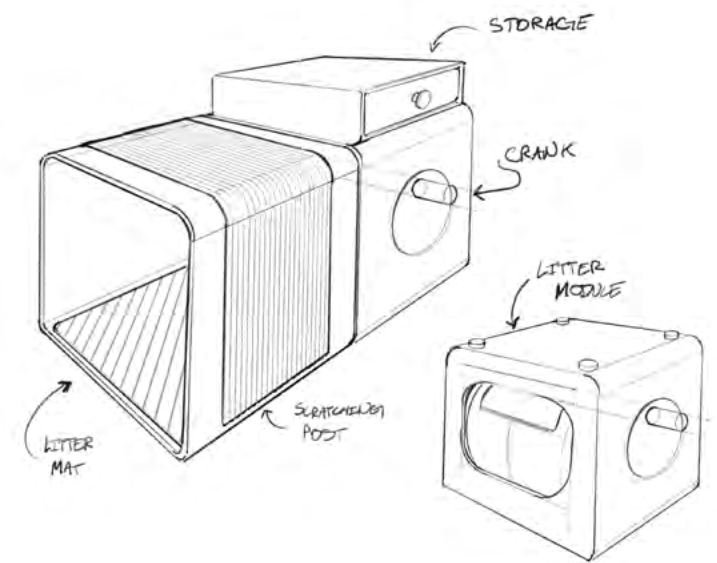
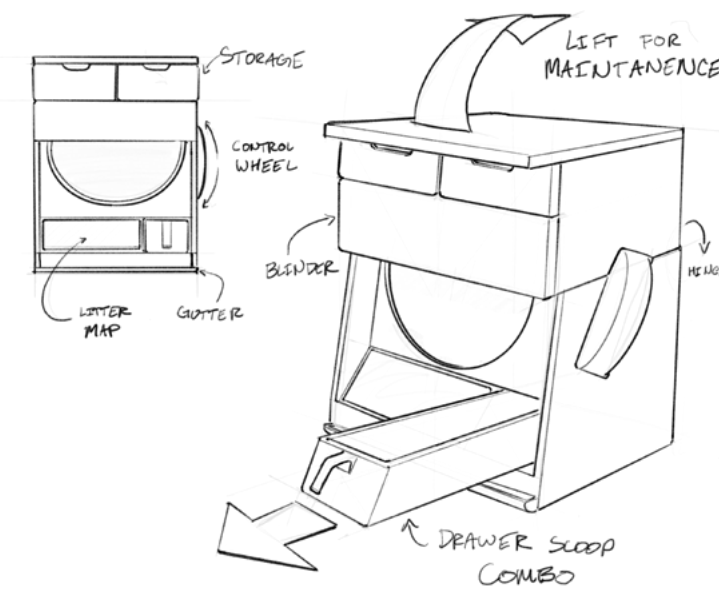
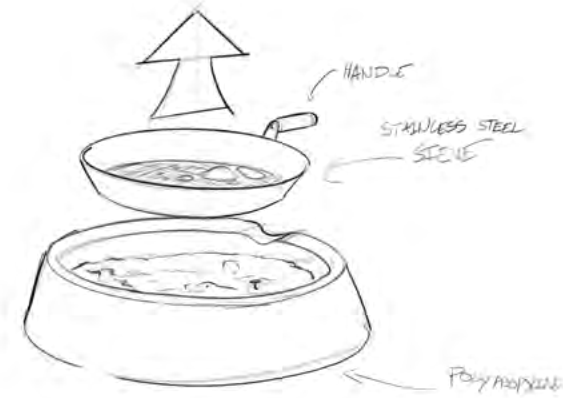
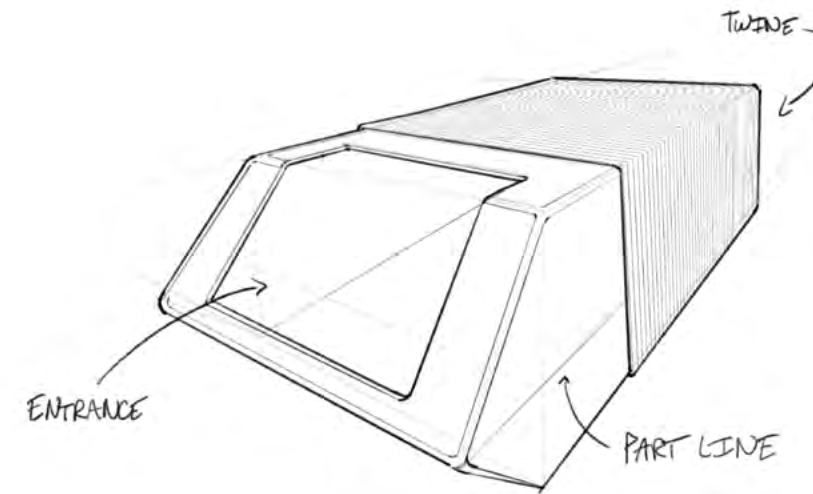
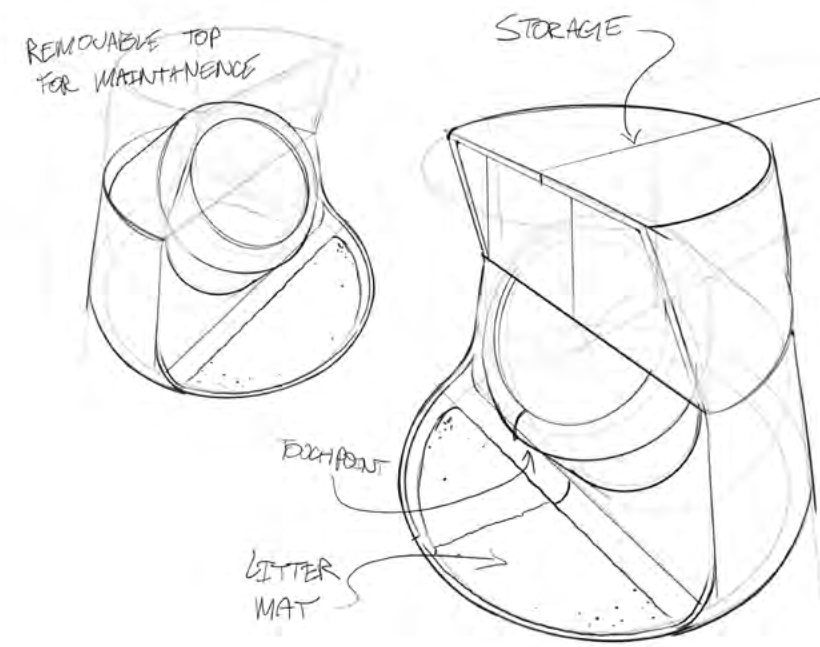
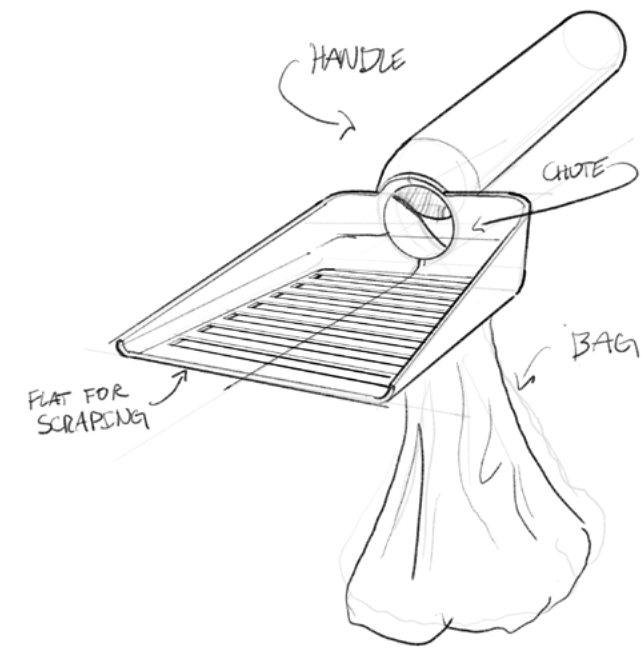
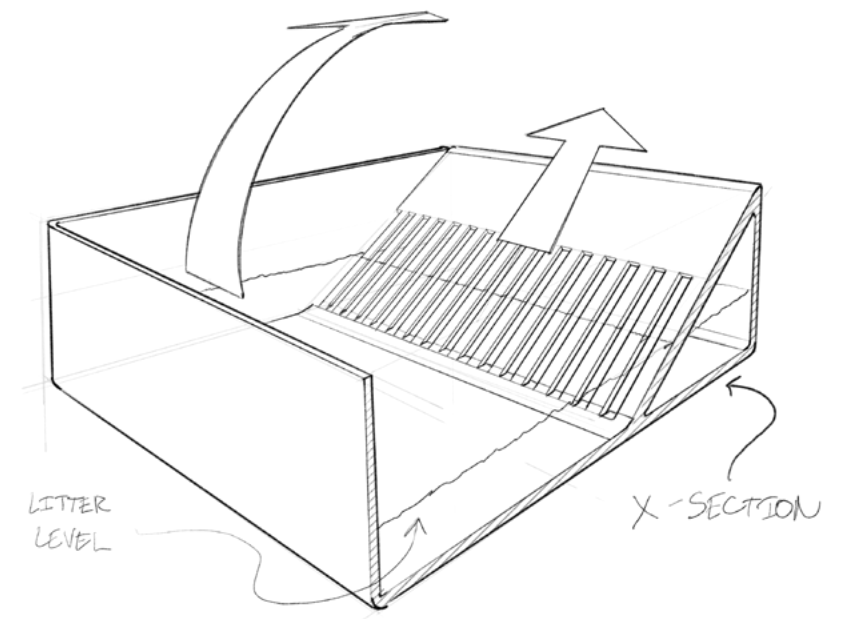
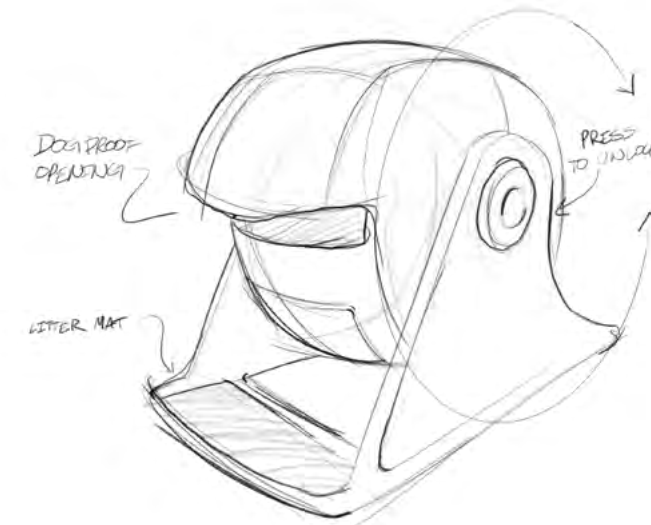
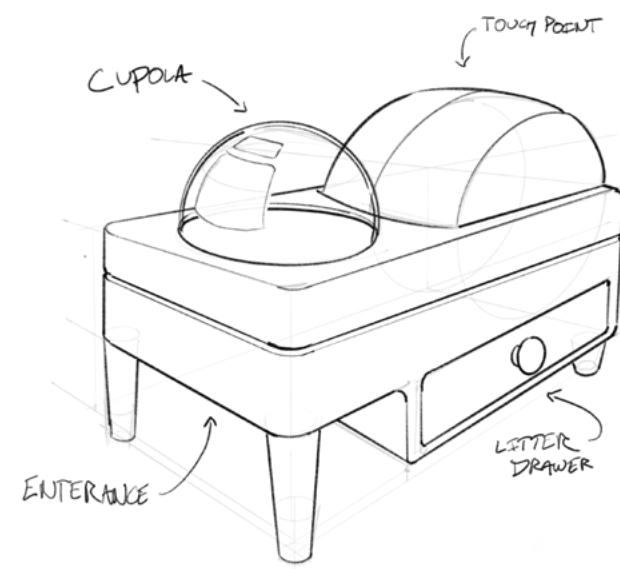
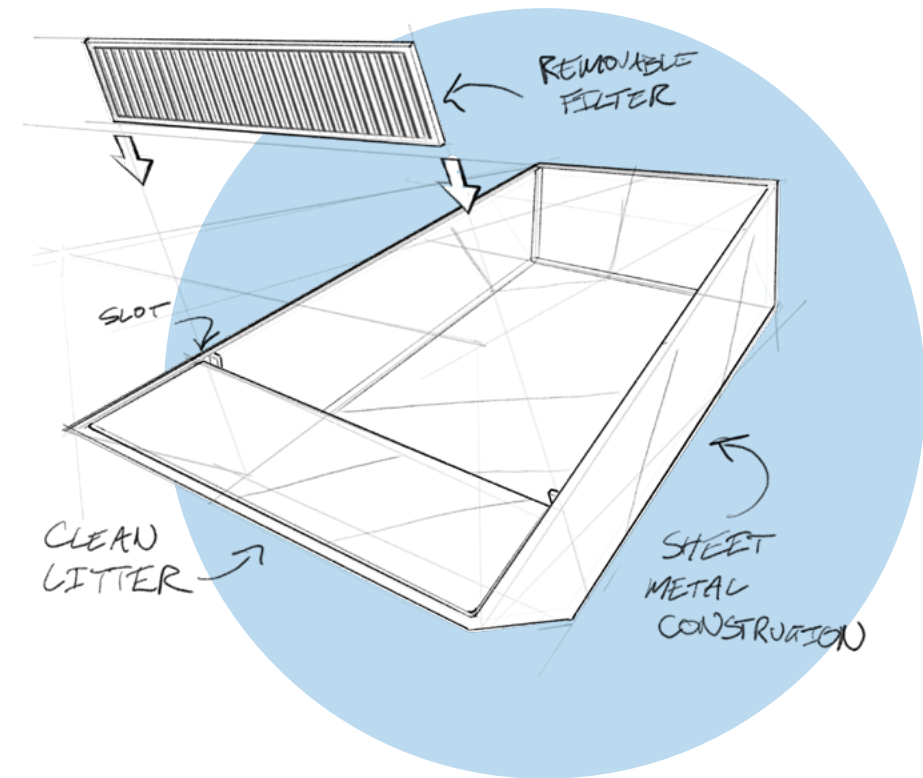
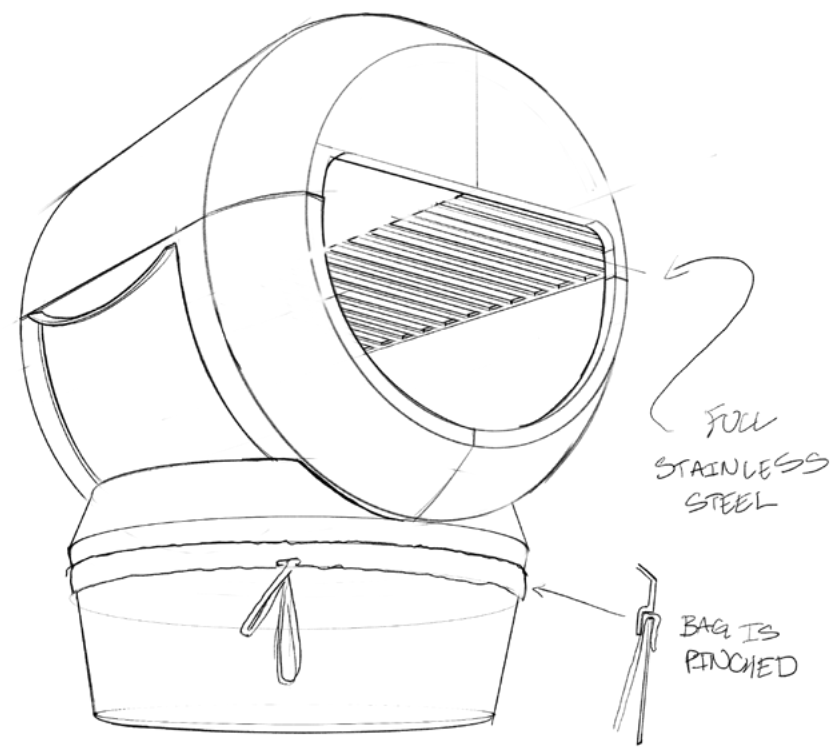

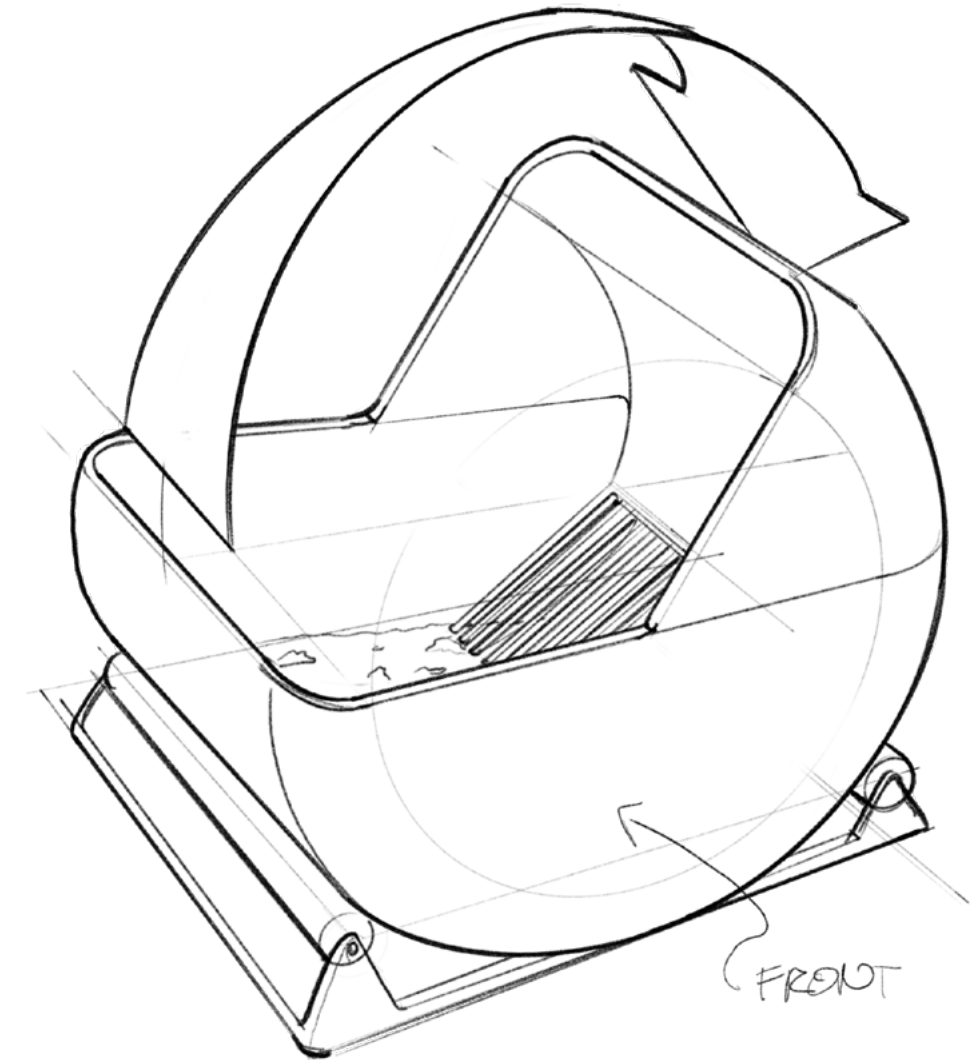
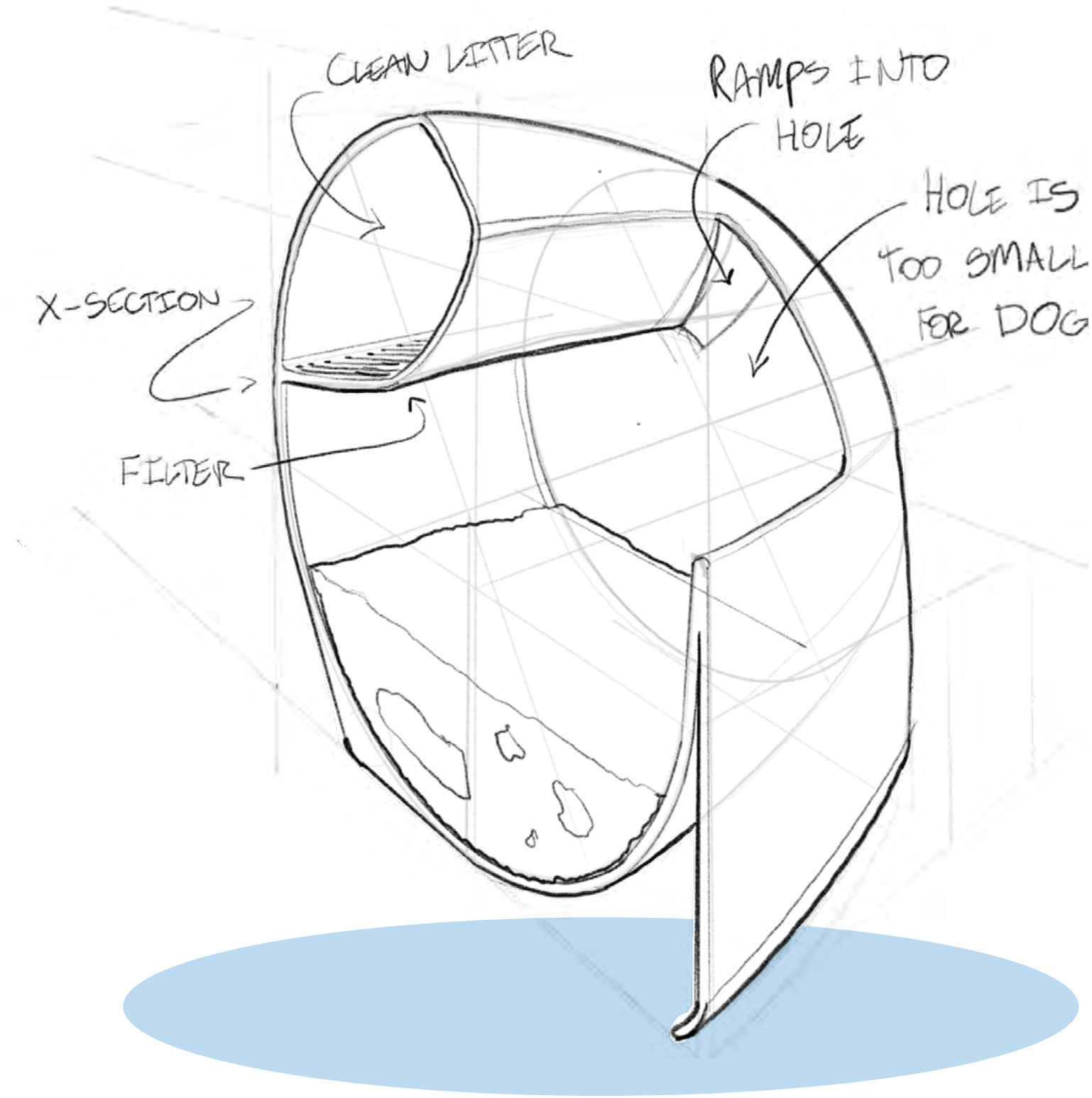
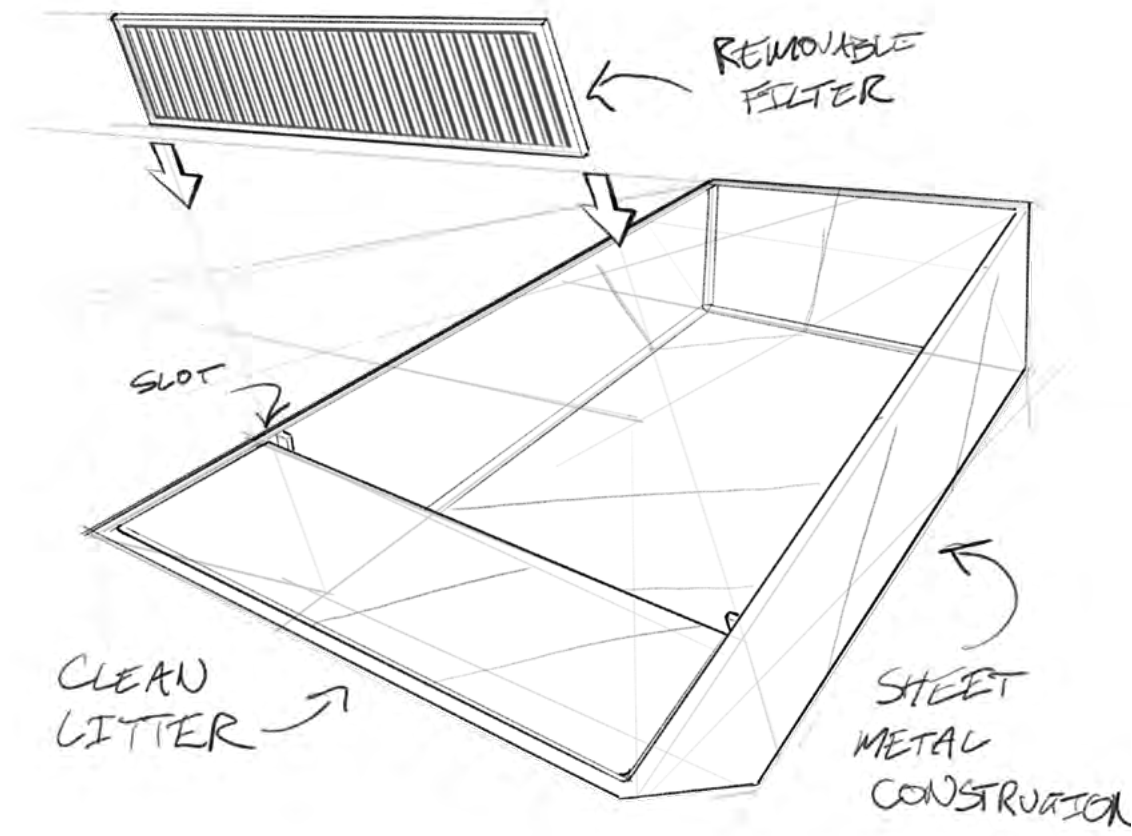

1

Super Simple

Pros

- Simple
- Clean
- Cheap

Cons

- No odor reduction
- Not dog-proof
- Needs bag

2

No Moving Parts

Pros

- Cheap
- Enclosed
- Simple

Cons

- Plastic (odor)
- Complex manufacturing
- Needs bag

3

Complex and Effective

Pros

- Easy to Maintain
- Enclosed
- Simple

Cons

- Unbalanced
- Many parts
- Not dog proof

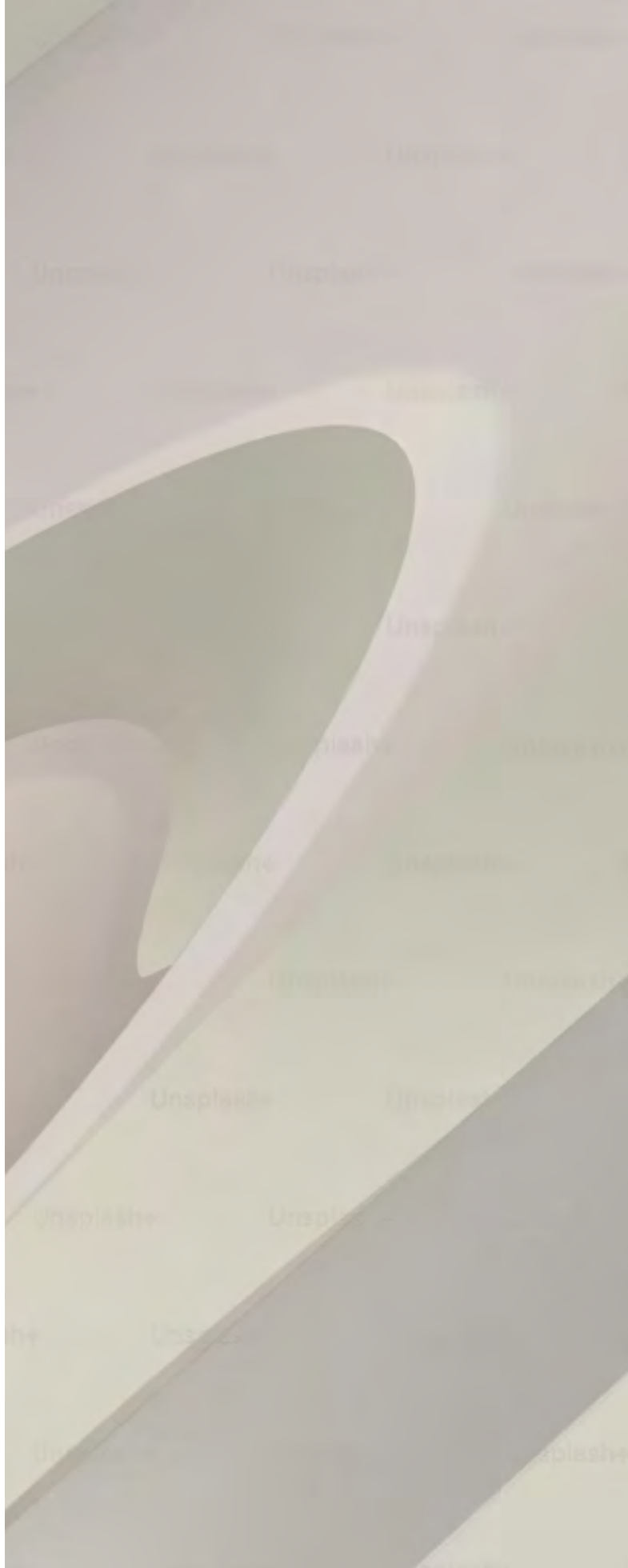
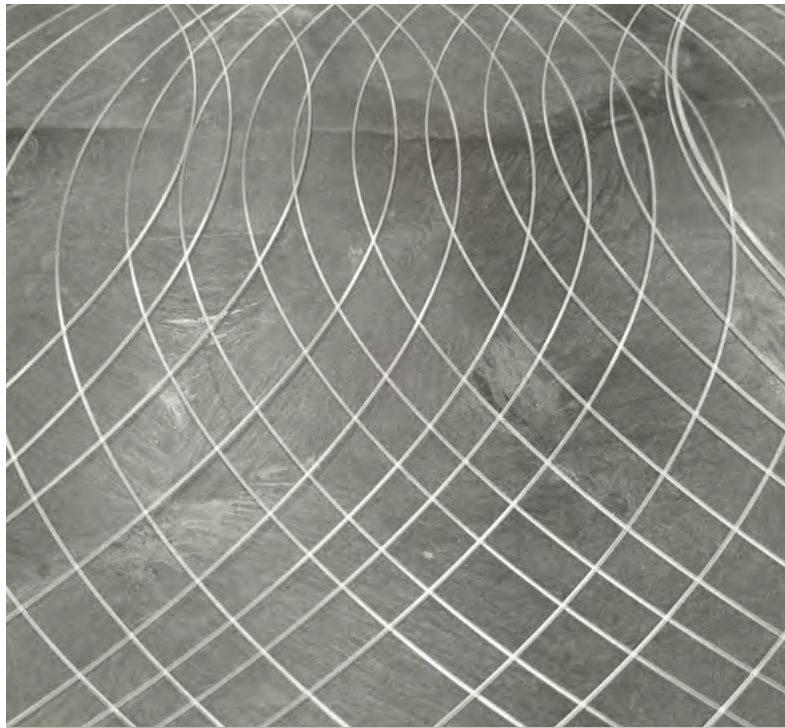

FLOW



SOFT ACCENTS

FULL METAL CONSTRUCTION

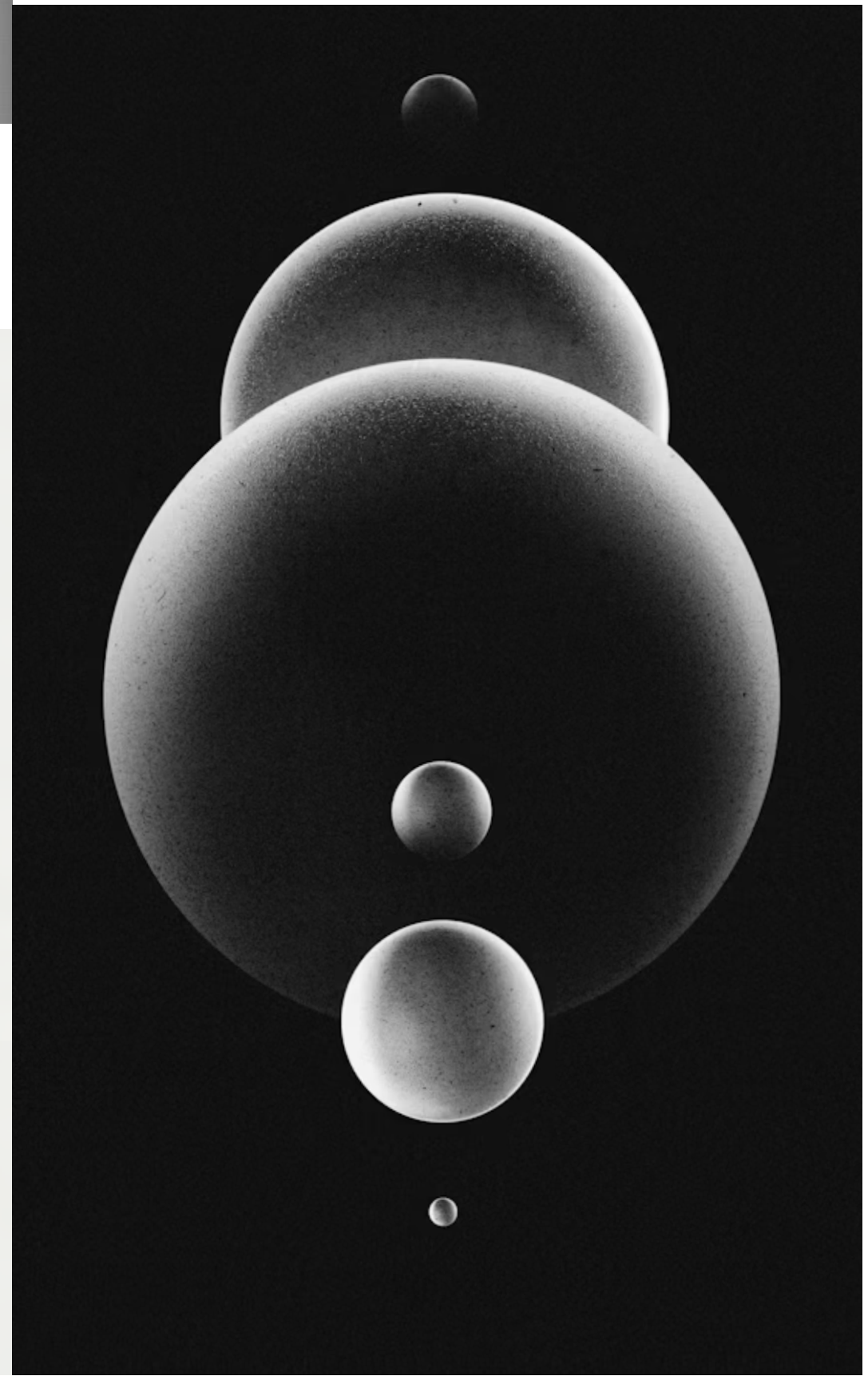

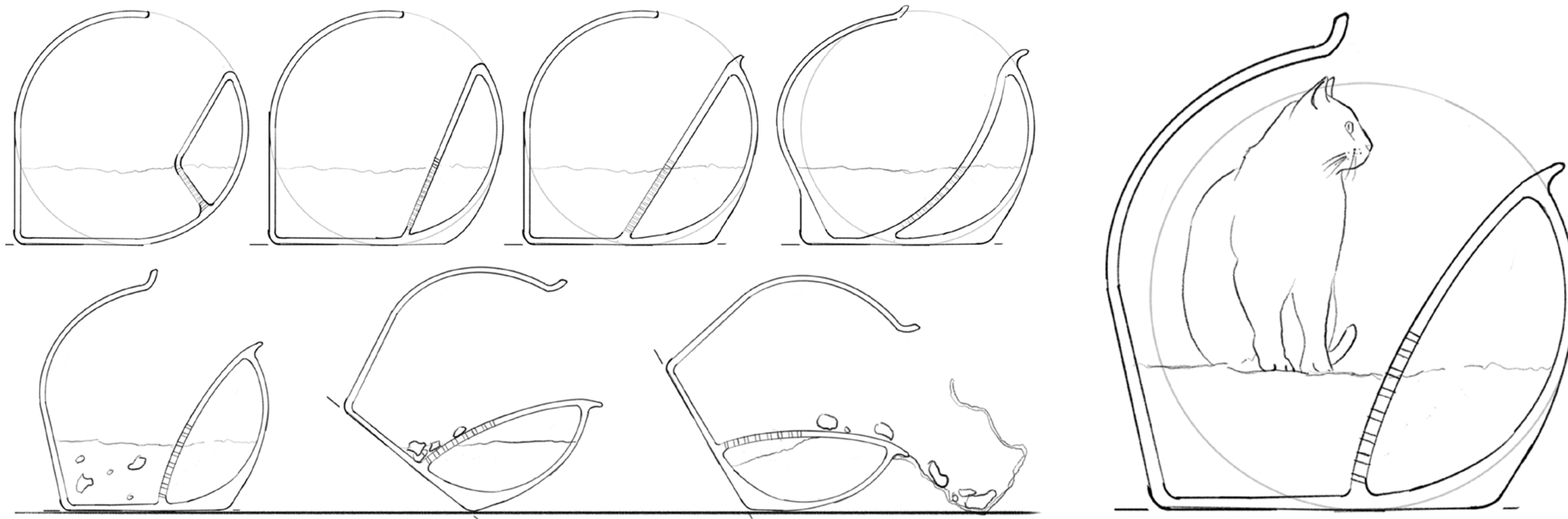

Profile Experimentation

How do we balance the total space inside with the size of the clean litter trap, while minimizing the tipping angle?

Handles

How can we add handles without puncturing the shell to contain the odor?

Potential CMF render

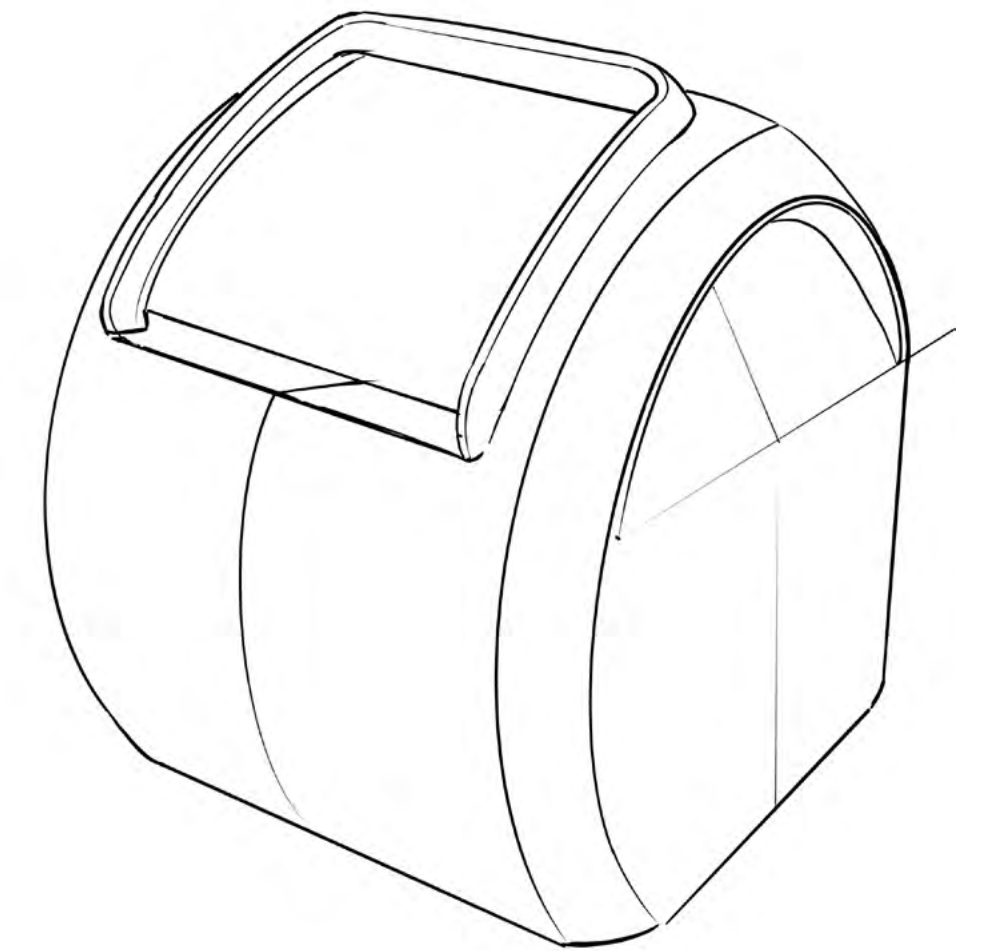
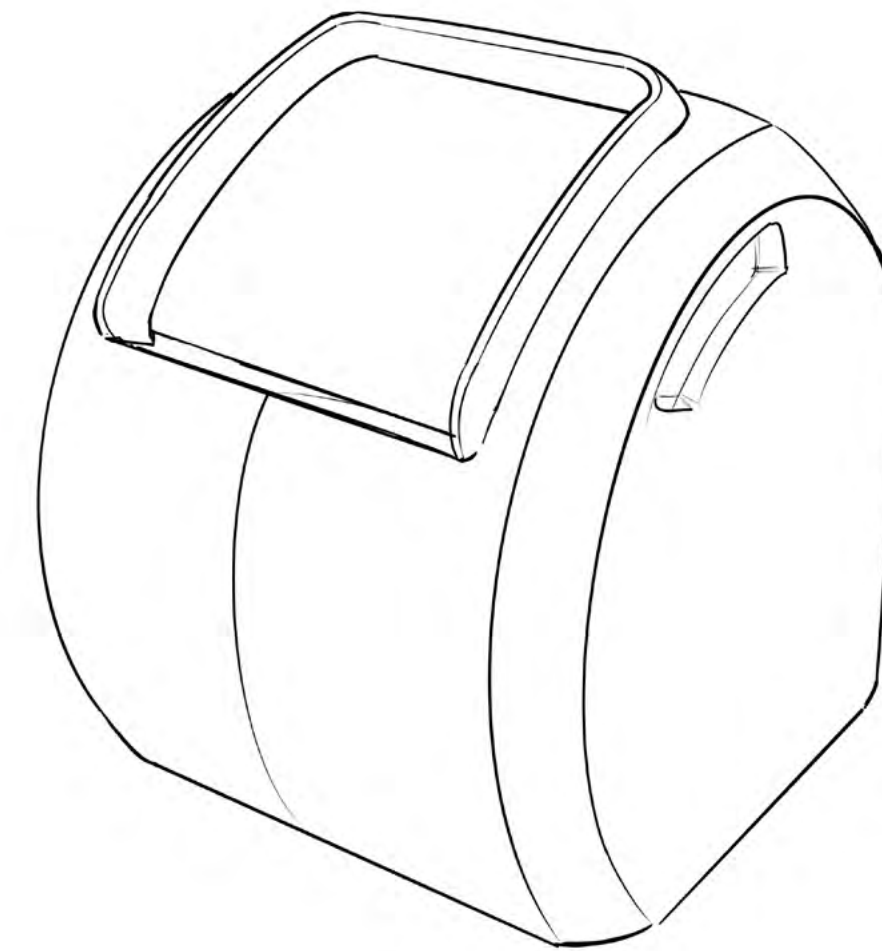
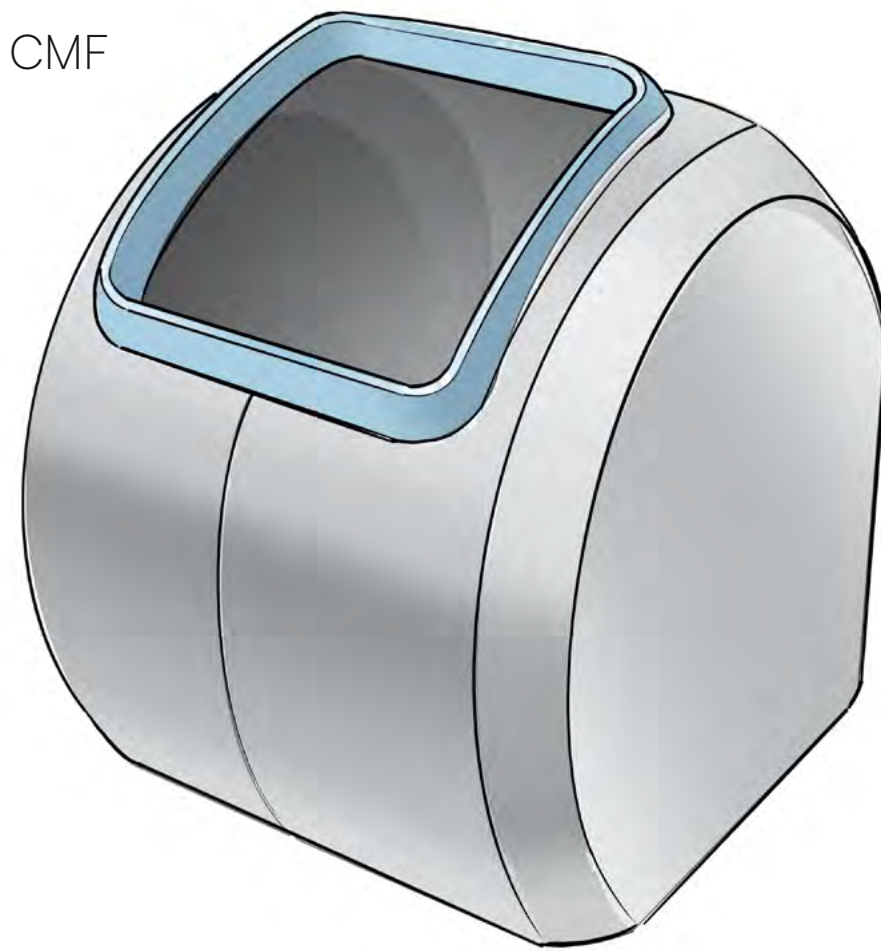

Issues with initial form:

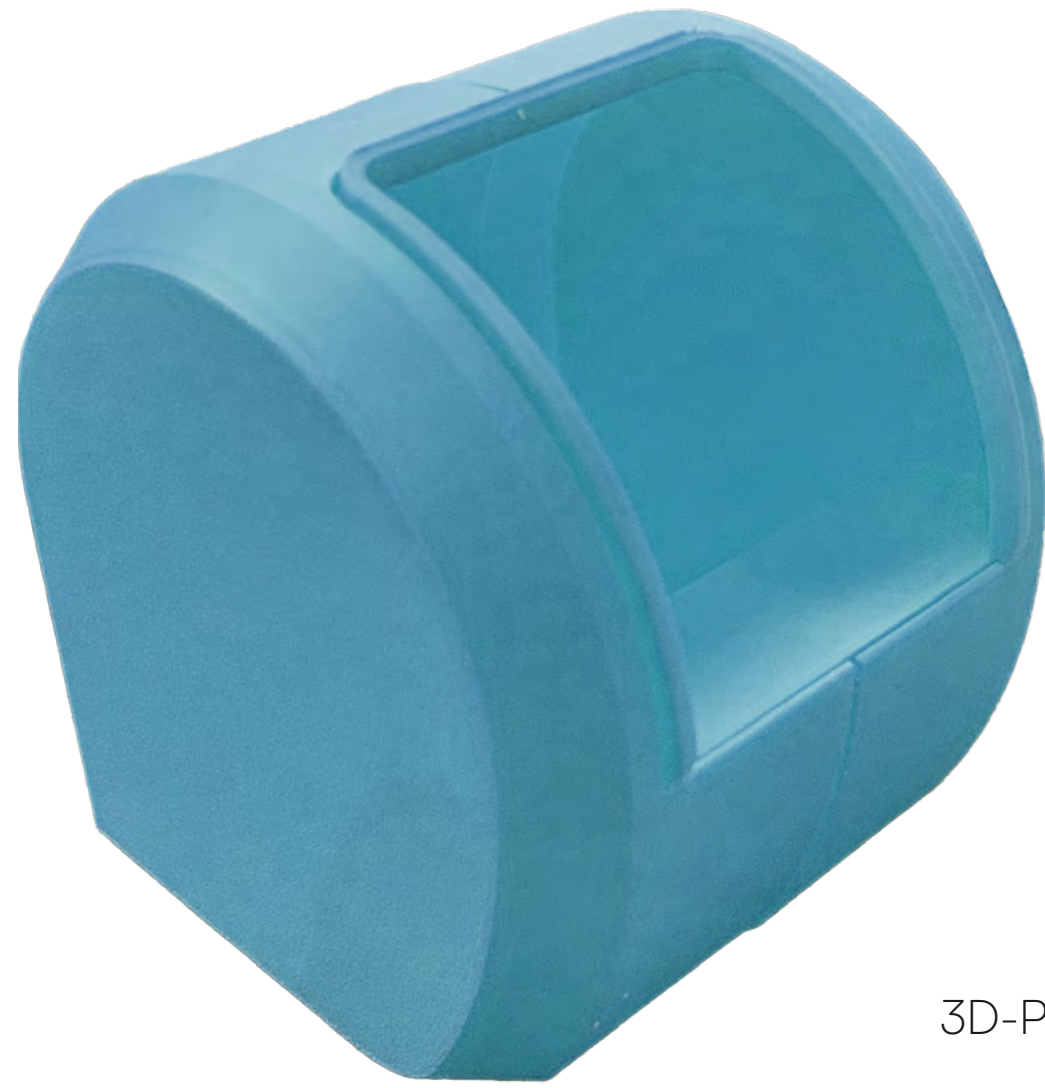

3D-Print

- The opening is too low to the ground when pouring
- Cats may hesitate when entering, as they can't see in before they enter
- The sagittal part line would cause the litter box to rock back and forth due to draft angles

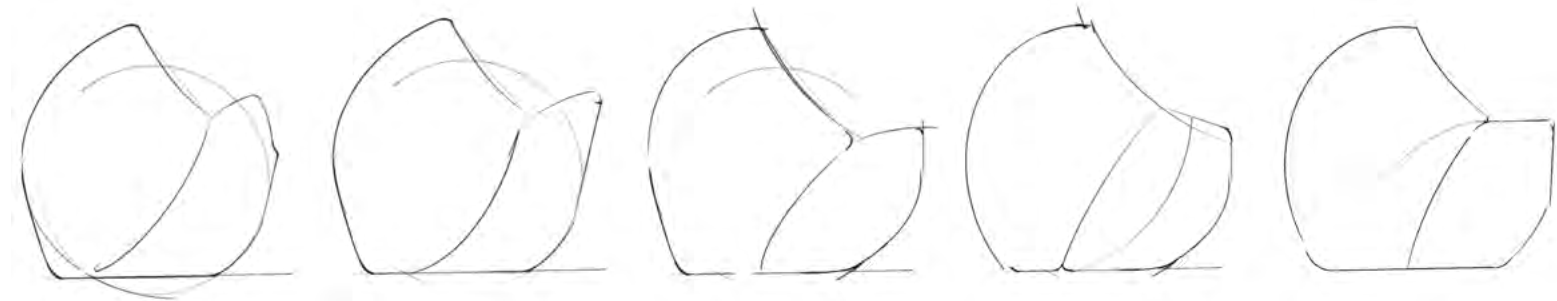

Further form development

Solution:

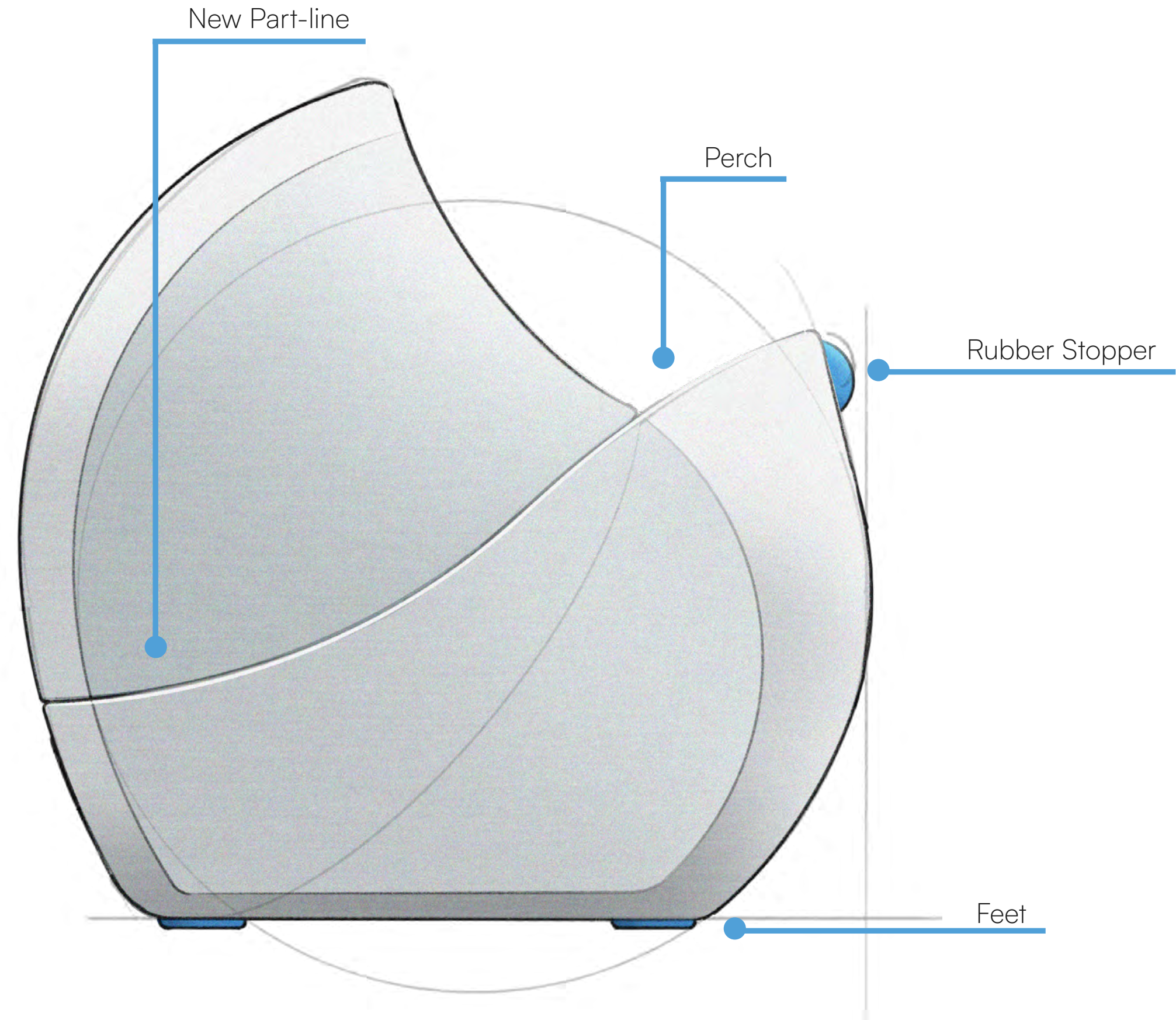

Manufacturable draft angles

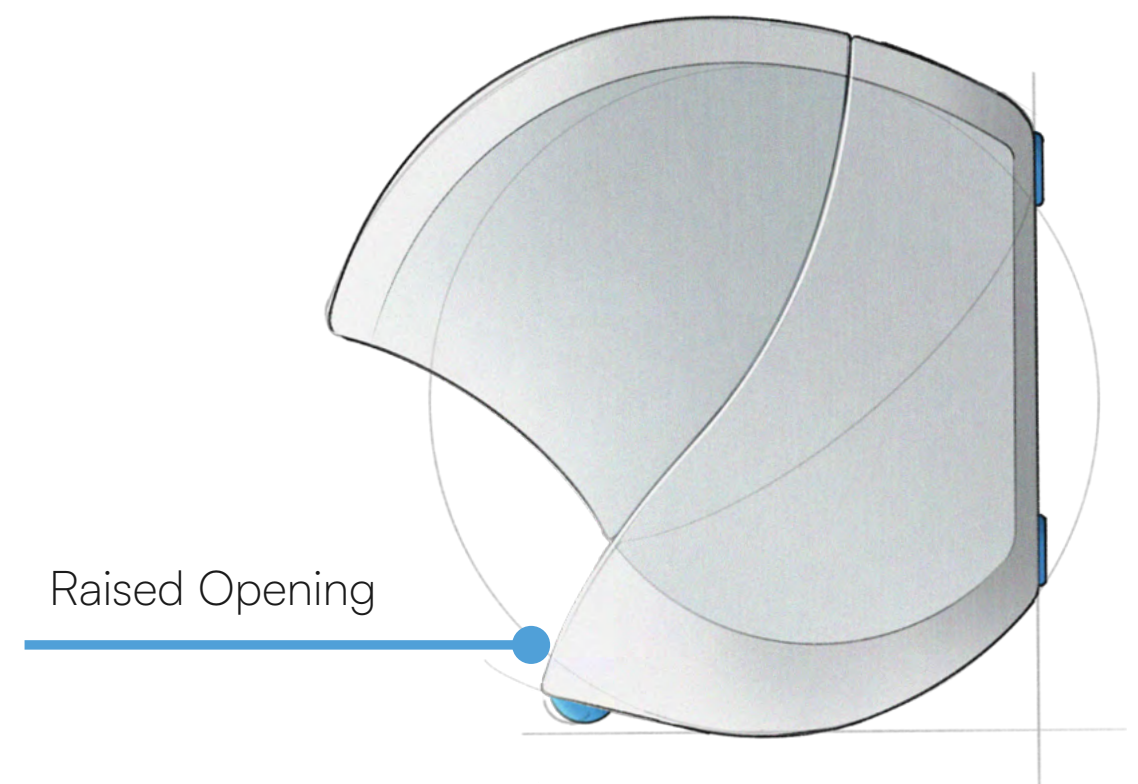
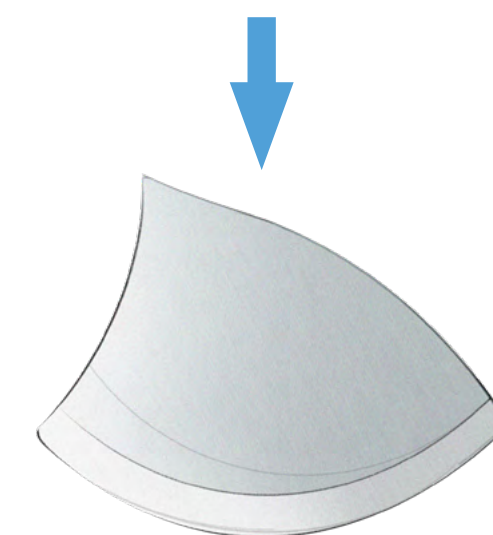
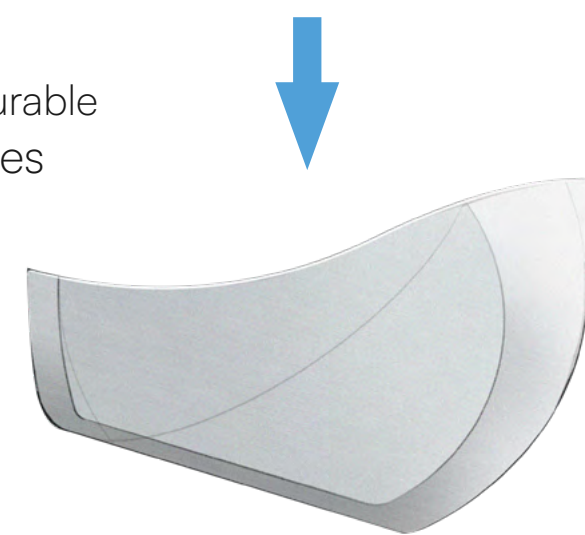

Further Refinement

Details

Experimented with different handles and bumpers

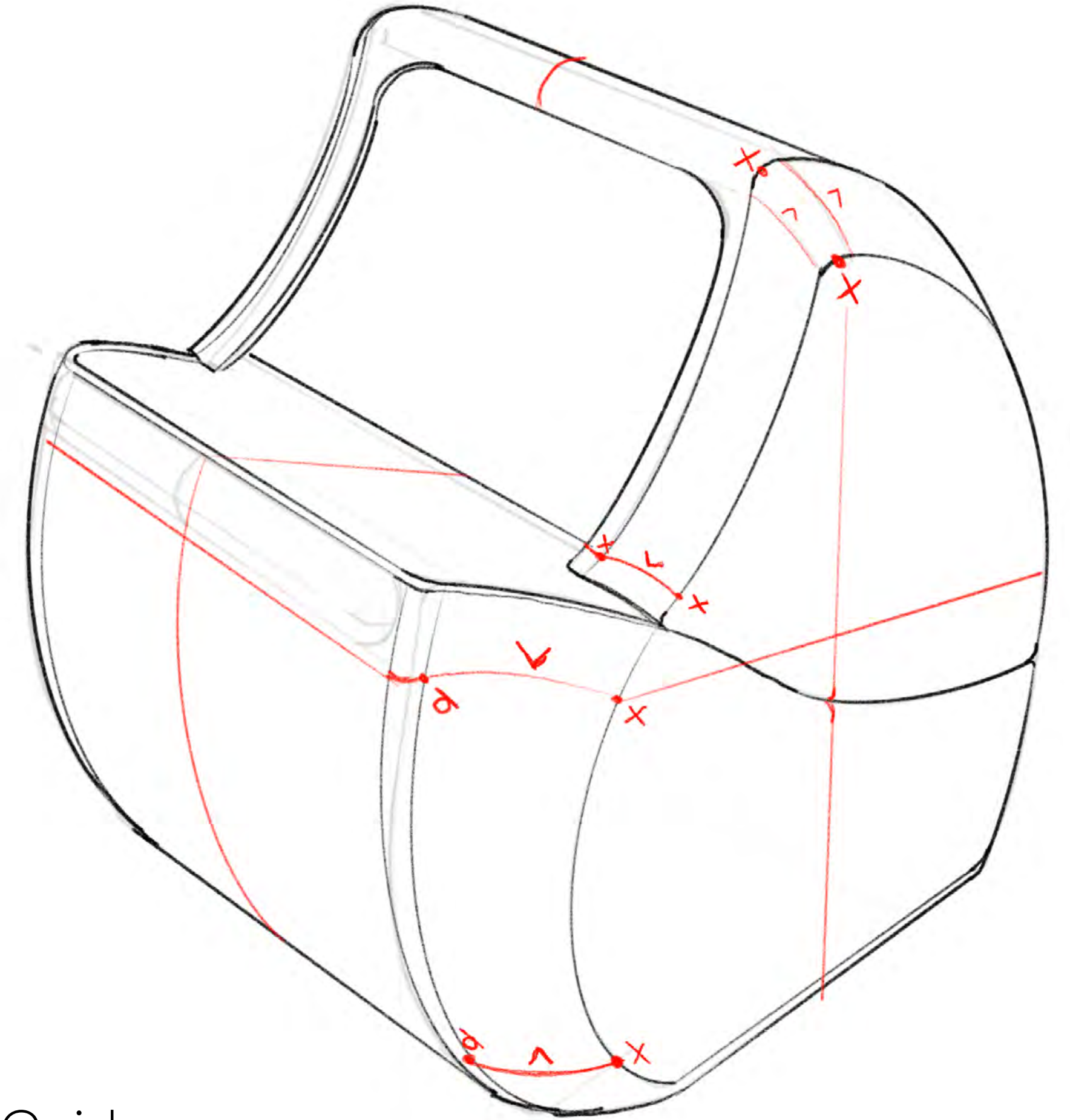
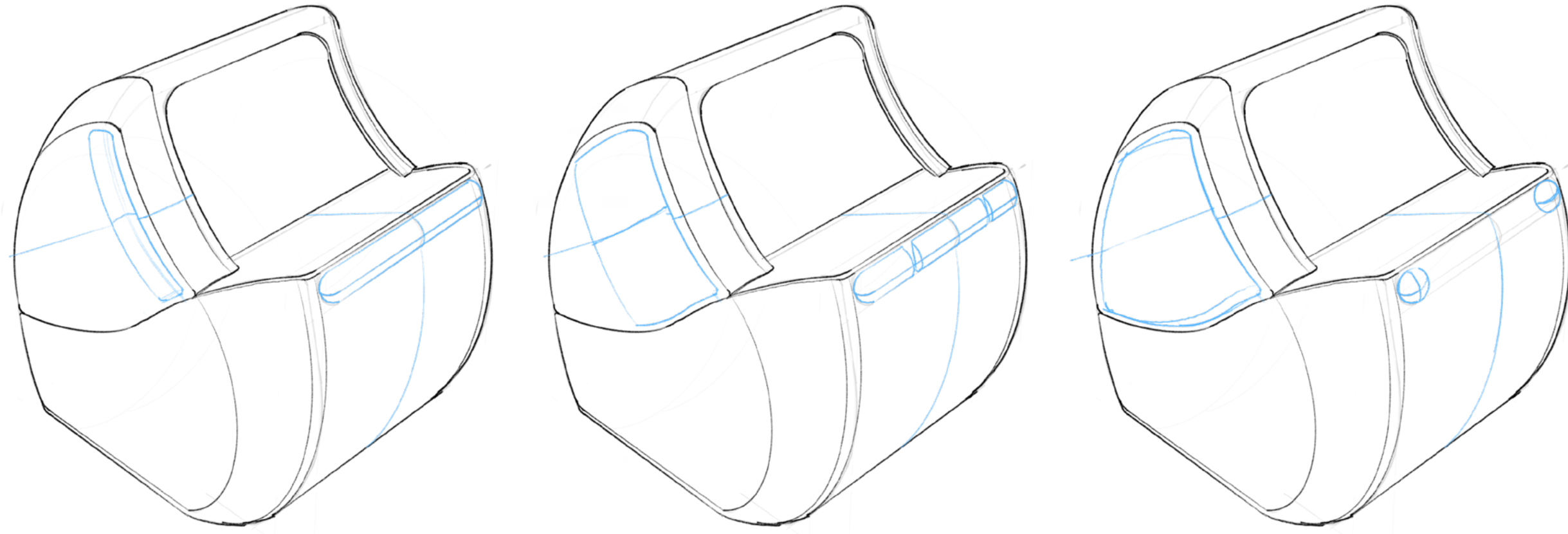

Surfacing Guide

Before transferring the sketch into CAD, I set myself up for success by verifying that the surfaces can work together in 3d



Tangent



Crease

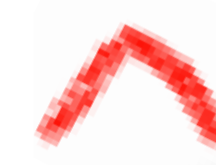

Convex



Concave

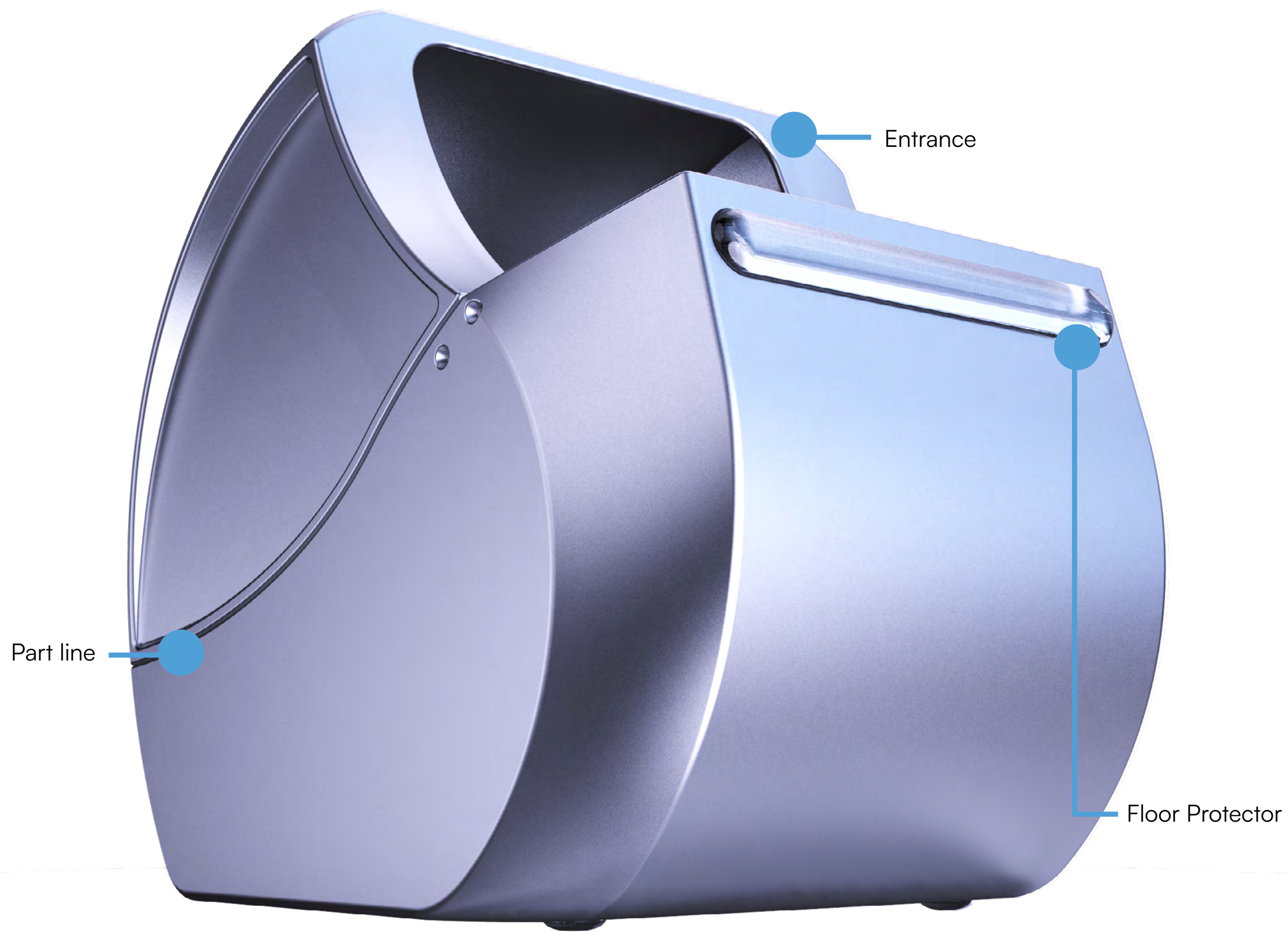

Front



Side



Bottom



Back

Instructions

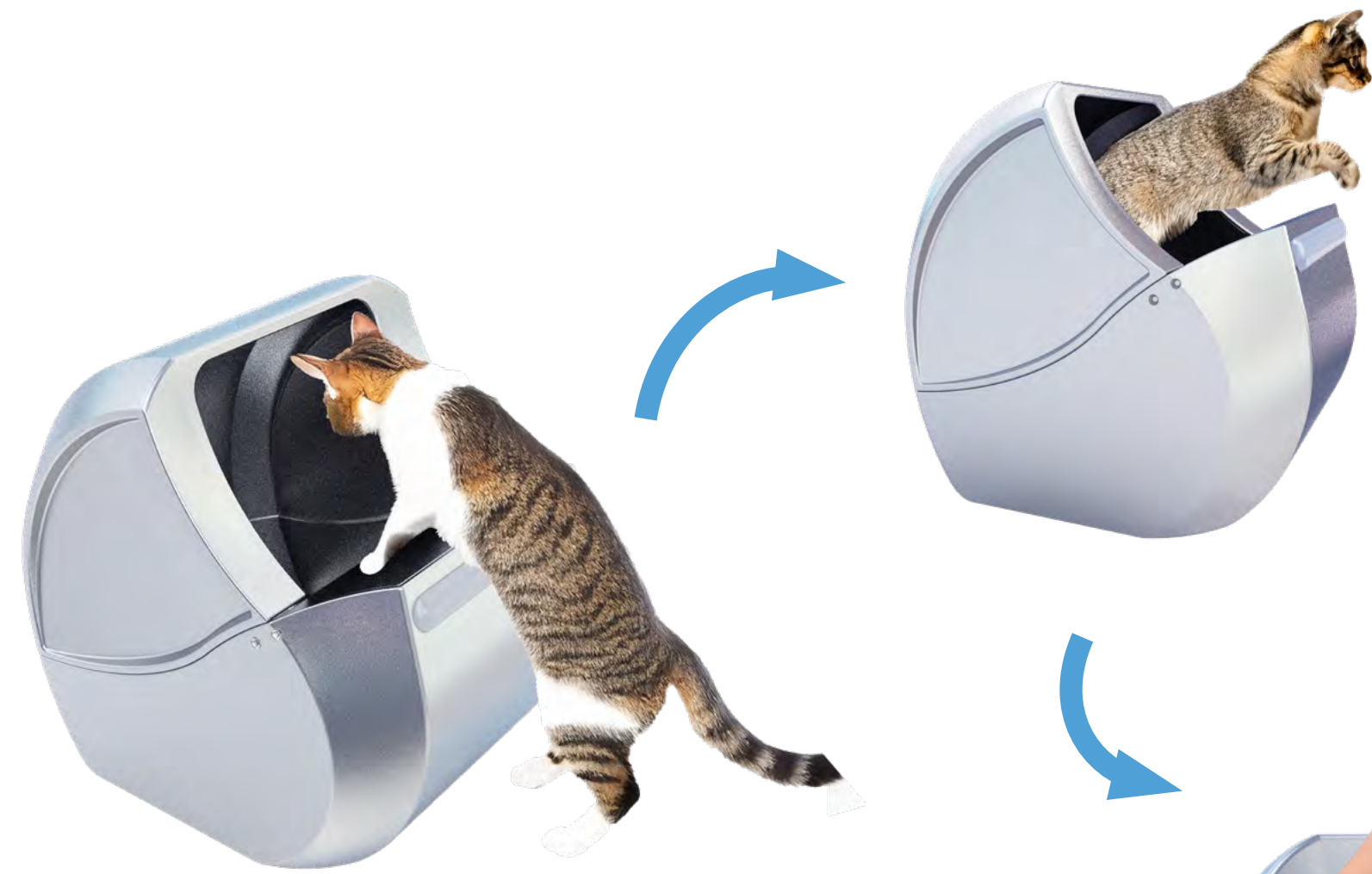

Cat enters litter box

Front platform serves as a perch for landing visibility



Cat exits litter box

Jumping lessens possibility of litter tracking



Place bag over opening

Hold a bag of your choice over the opening as you grip the side handles

Filtering

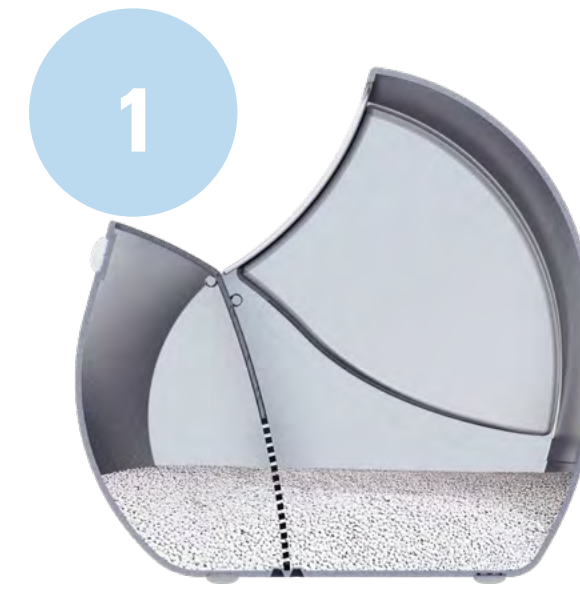

Disassembly

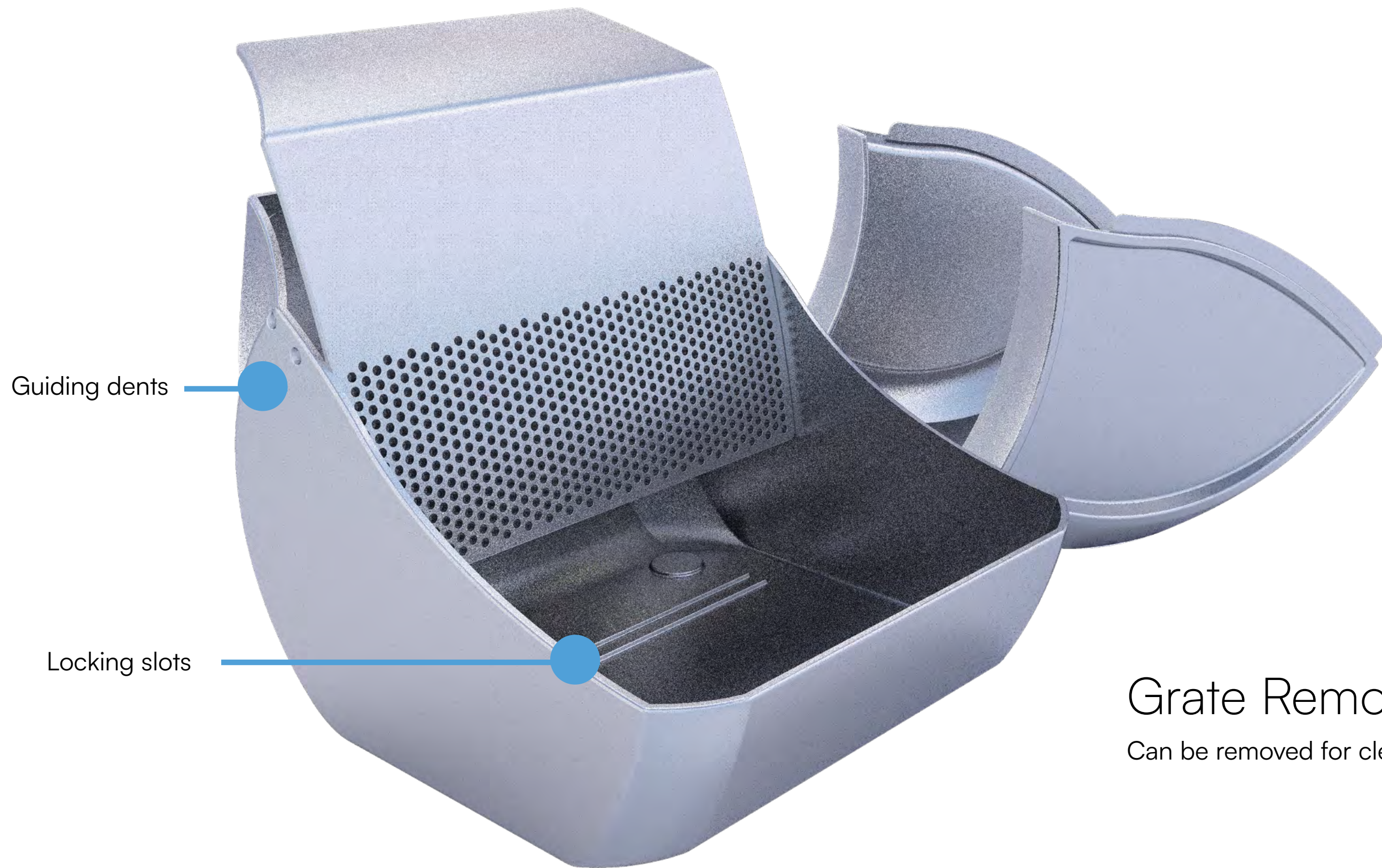

Guiding dents

Locking slots

Held in place by friction



Lid Removal

Removable for transport, cleaning, or open-top use

Grate Removal

Can be removed for cleaning with a shower head or hose

Manufacturing

Lid

It can be stamped out of sheet metal in three stages. First, the main shape, then the connecting lip, and finally the side handle indents.



Base

It is first stamped into the main shape, similarly to a metal bowl. Then, cavities for the four feet and the stopper are punched out along with the guides for the grate.



Grate

Metal holes are laser cut in a single piece of sheet metal, which is then bent once using a brake.

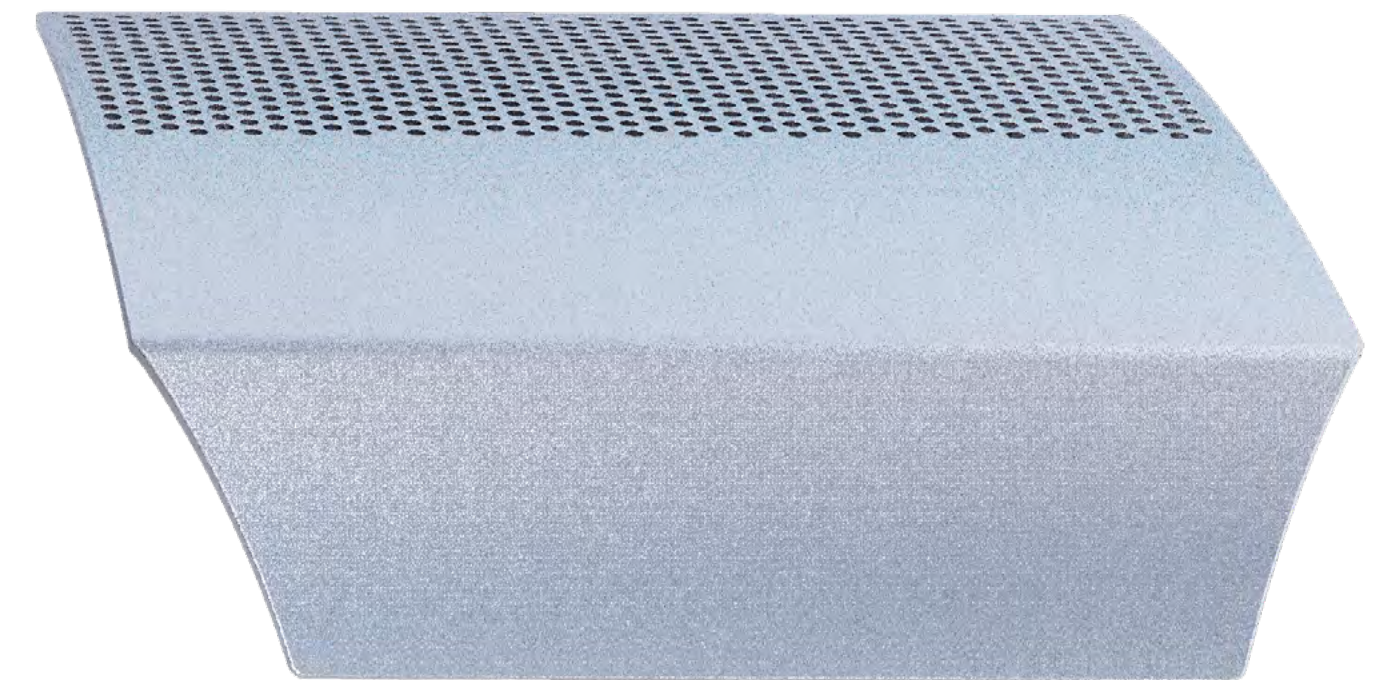

Next Steps...

Adapt form to fit manufacturing methods

Experiment with handles in the base

Discuss benefits of metal vs a cheaper plastic



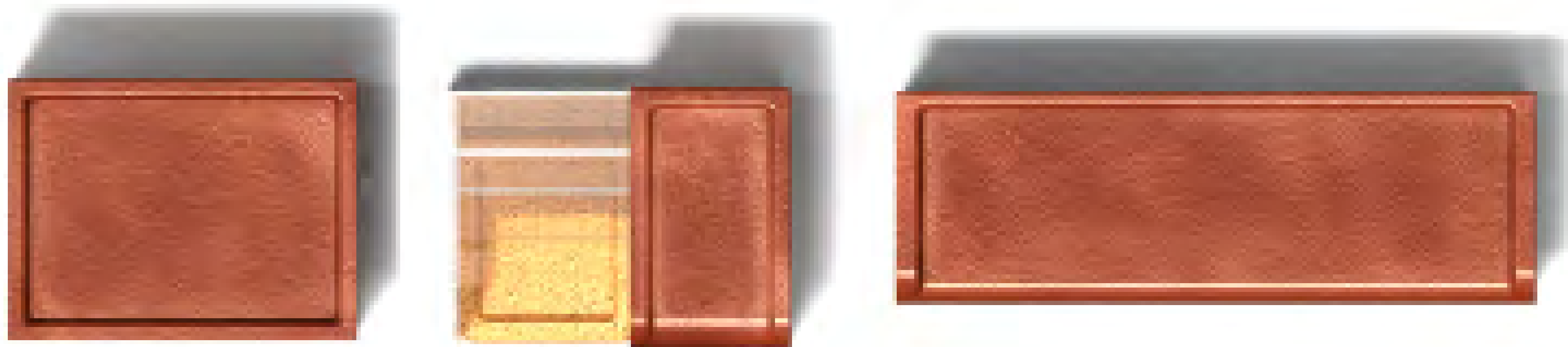

MUJI
無印良品

Desk Accessories

Creating a naturally
organized space

2026 - 4 Weeks



Where they **are**



Where they **want to be**

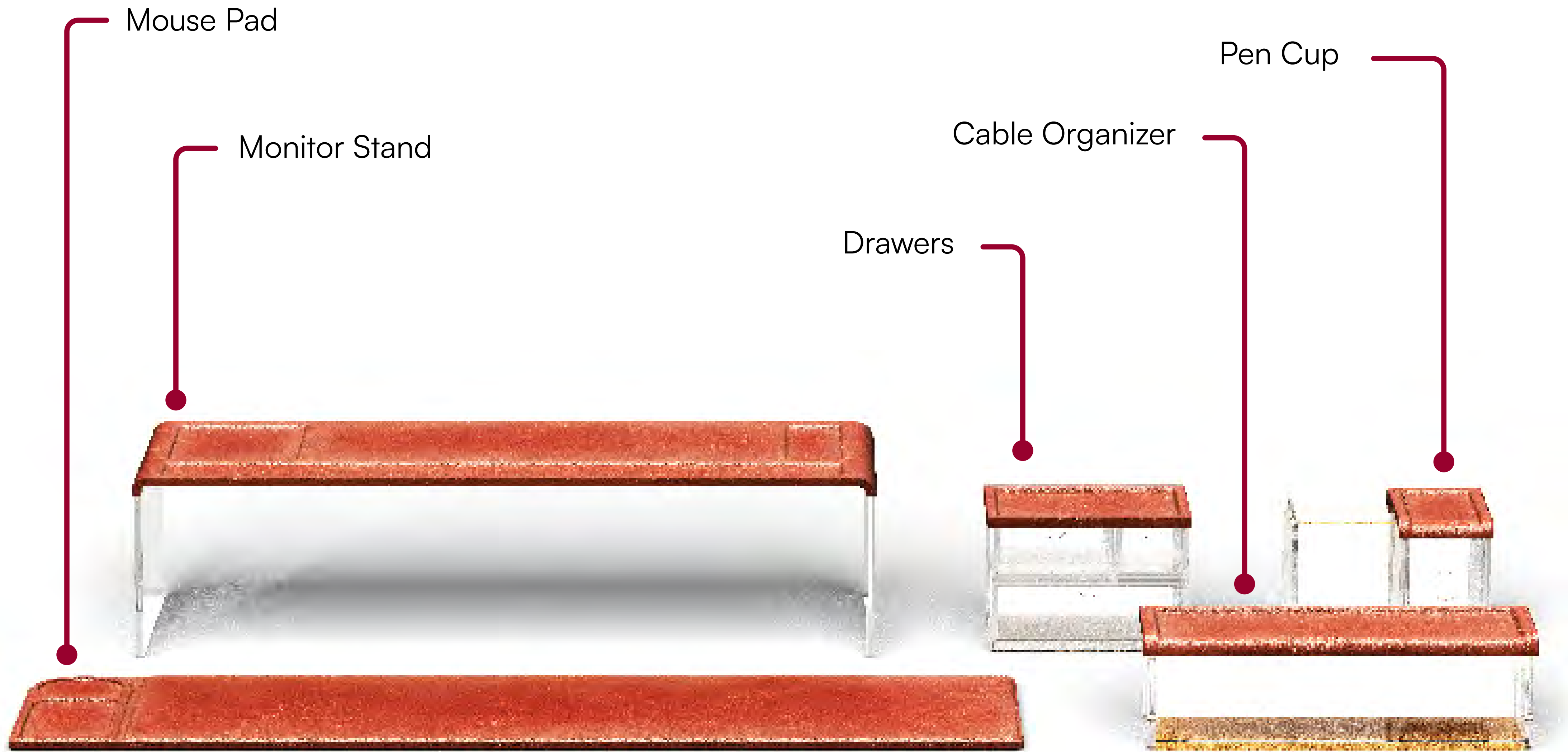

Mouse Pad

Monitor Stand

Drawers

Cable Organizer

Pen Cup





Mouse Pad



Glued over plastic spacer

2 sheets of 6oz leather

Cork backing



In Context

Monitor Stand

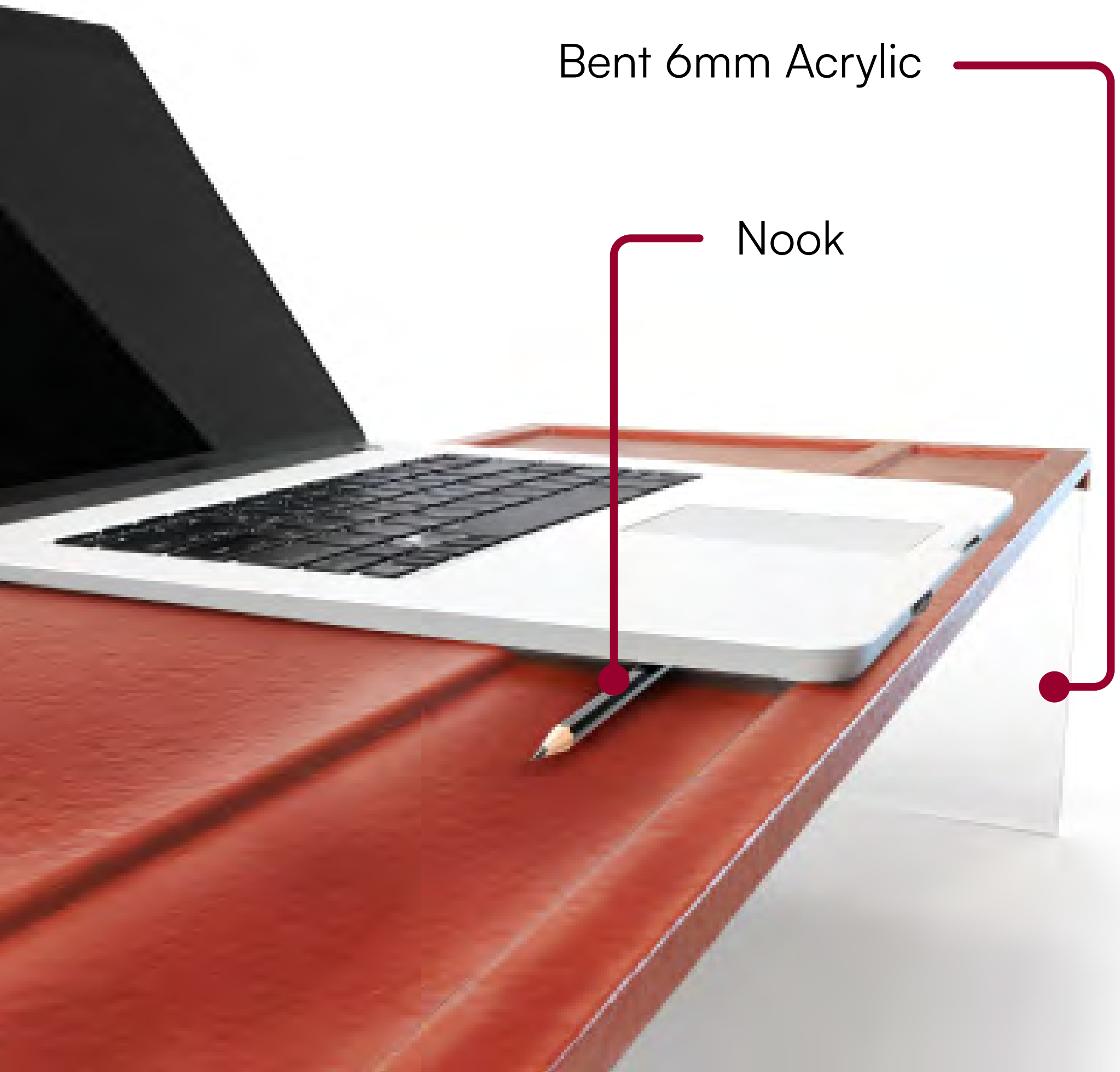

Bent 6mm Acrylic

Nook



Monitor



Laptop

Pen Cup



Priority Storage



Cork Catchall

Spot for Phone

Drawers



In Context

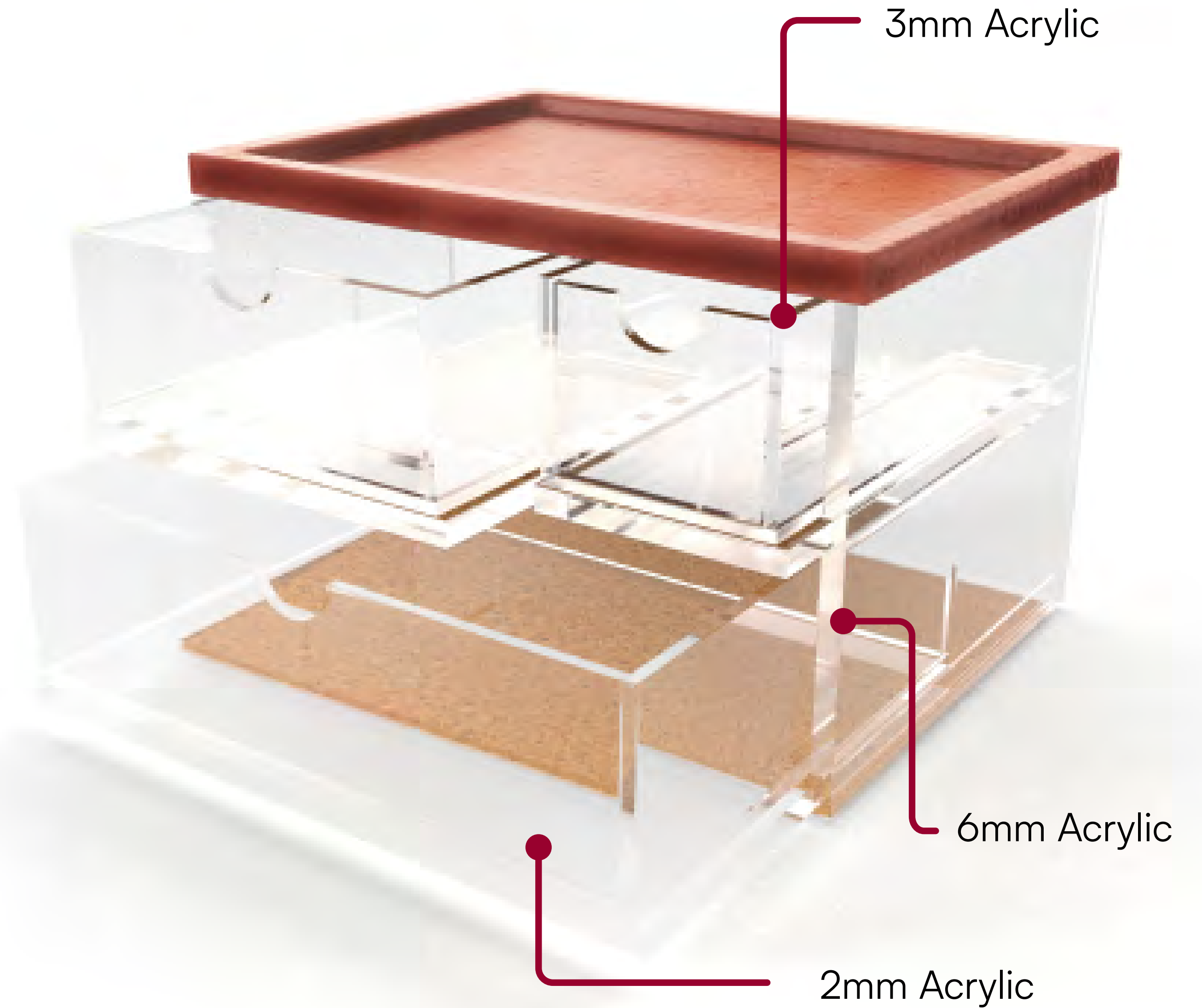

Cable Organizer

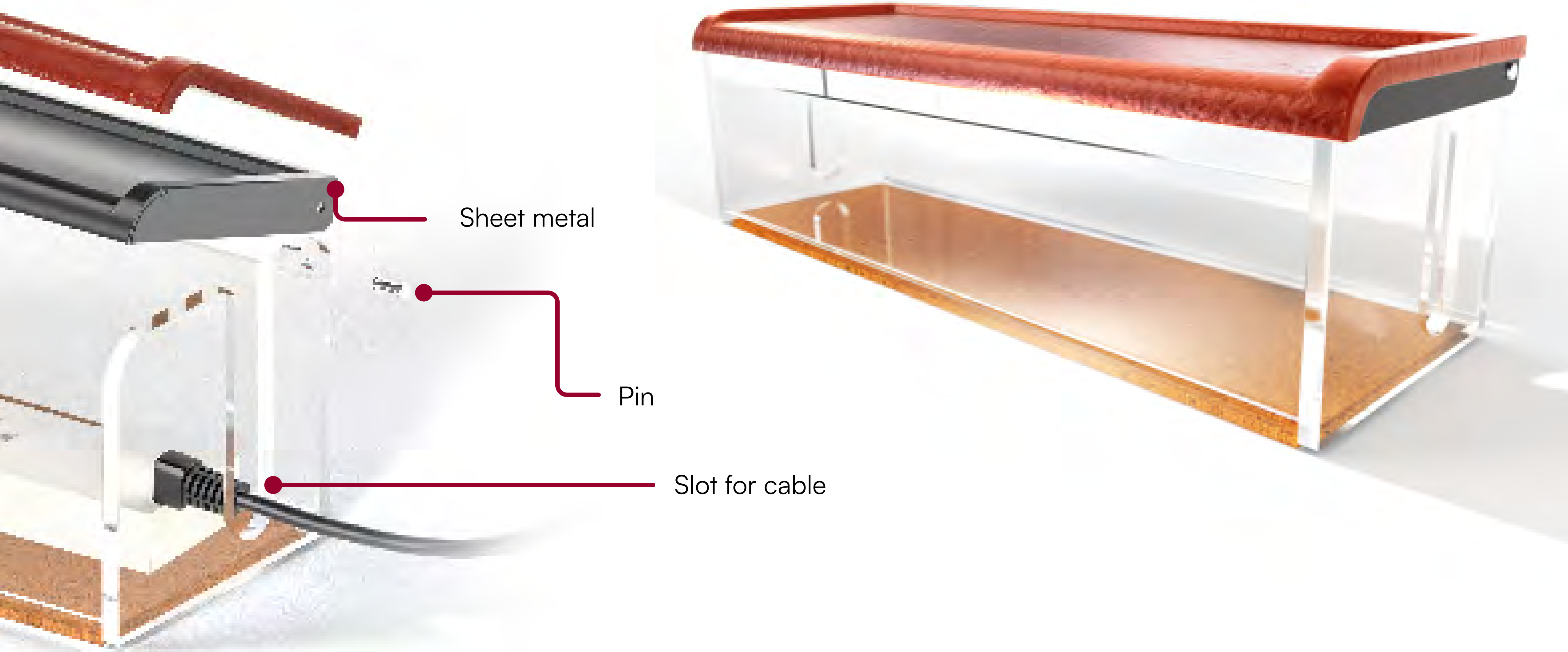

The background features several rectangular panels with a brown, leather-like texture. Some panels have thin gold borders. The panels are arranged in a grid-like pattern, with some partially cut off by the edges of the frame. The overall aesthetic is classic and elegant.

Next steps...

Refine acrylic construction methods

Dial in leather thickness and molding process

Avoid top heavy forms